

Digitized by ASSOCIATION FOR PRESERVATION TECHNOLOGY, www.apti.org for the
BUILDING TECHNOLOGY HERITAGE LIBRARY
<https://archive.org/details/buildingtechnologyheritagelibrary>
From the collection of Alan O'Bright

100

BETHLEHEM STRUCTURAL SHAPES

GIRDERS, BEAMS,
STANCHIONS OF HEAVY WEIGHTS
AND
H COLUMNS

Catalogue No. S-34

Supplement to Catalogue S-27 Entitled
BETHLEHEM STRUCTURAL SHAPES

Dated January, 1928

BETHLEHEM STEEL COMPANY

General Offices

BETHLEHEM, PA.

INTRODUCTION

This catalogue is a supplement to Catalogue S-27 entitled BETHLEHEM STRUCTURAL SHAPES dated January 1928, and it cancels and supersedes the previous supplement S-29 of March 15, 1928.

It presents revised information relating to Bethlehem 36, 33, 30, 28, and 22 inch I Beams and Girders and also includes data relating to two new series of Column sections, namely, 10 inch columns numbered $H_{10}^{\frac{1}{2}}$ and 6 inch Stanchions of heavy weights numbered $H_6^{\frac{1}{2}}$.

The data given include drawings of these sections together with their dimensions, weights, properties, tables of safe loads, and other useful information.

New sections have been added to the former Bethlehem series and five sizes have been revised, these changes being as follows:—

ADDED AND REVISED SIZES AND WEIGHTS

GIRDER BEAMS.

- G 36 weighing 300 and 280 pounds per foot and a revised size weighing 230 pounds per foot.
- G 33 weighing 260 and 245 pounds per foot and a revised size weighing 200 pounds per foot.
- G 30 weighing 240 and 220 pounds per foot.
- G 28 weighing 186 pounds per foot.
- G 22 weighing 132 pounds per foot.

I BEAMS.

- B 36 weighing 190 pounds per foot.
- B 33 weighing 165 pounds per foot.
- B 30 weighing 163, 149, and 137 pounds per foot.
- B 28 weighing 133, 119, and 85 pounds per foot.
- B 22 weighing 54.5 pounds per foot.

Dimensions of B 36—147 pounds per foot, B 33—152 and 125 pounds per foot have been slightly modified, the weights remaining as in Supplementary Catalogue S-29.

ADDED AND REVISED SIZES AND WEIGHTS
(Concluded)

H COLUMNS AND STANCHIONS.

$H_{1\frac{1}{2}}^0$ —A new series of Bethlehem H Columns comprising 26 sections weighing from 62 to 246 pounds per foot.

$H_{1\frac{1}{2}}^6$ —A new series of Bethlehem Stanchions, heavy weights, comprising 8 sections weighing from 40 to 88 pounds per foot.

In presenting the additional sections of Bethlehem Wide Flange Beams and Girders, the previous weights that are retained in each series have also been included in the tabulations in order to give complete information, thereby avoiding unnecessary reference to the original catalogue S-27.

In computing the weights and properties of all sections the fillets have been included.

The slope of the flanges of all Bethlehem Girder and I Beams is 8-1/3 per cent or 1 in 12 and that of the H Columns and Stanchions is 2 per cent or 1 in 50.

The dimensions, areas, and weights presented herein are theoretical and subject to the usual variations.

These sections are steel and their weights are calculated on the basis of 489.6 pounds per cubic foot; and 3.4 times the sectional area, in square inches, equals the weight in pounds per linear foot.

All of the sections are numbered for convenience and identification in ordering.

These sections are protected by United States Letters Patent.

BETHLEHEM STEEL COMPANY.

Bethlehem, Pennsylvania.

January, 1930.

GENERAL CONDITIONS.

ALLOWABLE VARIATIONS.

The shapes shown herein will be cut to ordered length with an allowable variation either way within $\frac{1}{2}$ inch.

For cutting with less variation, or to exact length, an extra price is charged.

These shapes are billed and charged at catalogue weights and may have an allowable variation of $2\frac{1}{2}$ per cent either way from the nominal section.

MATERIAL.

All Structural Shapes manufactured by Bethlehem Steel Company are of steel conforming to the Manufacturers' Standard Specifications, and to those of the American Society for Testing Materials.

Material complying with any other standard specifications may be furnished by special arrangement.

WEIGHTS AND DIMENSIONS
OF
BETHLEHEM GIRDER BEAMS,
BETHLEHEM I BEAMS,
BETHLEHEM H COLUMNS,
AND
BETHLEHEM STANCHIONS.

BETHLEHEM GIRDER BEAMS.

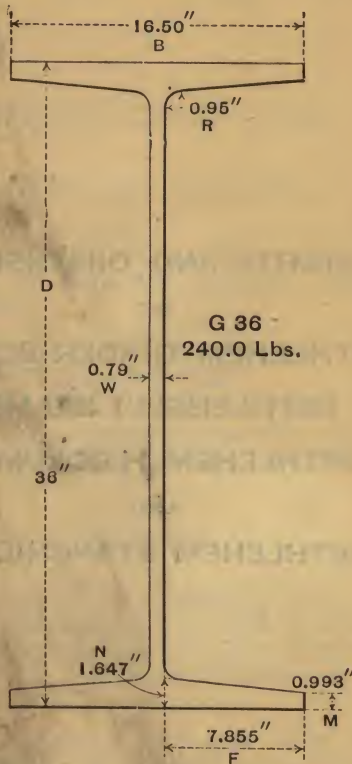

Section Number.	Weight per Foot, Pounds.	Nominal Depth of Beam, Inches.	DIMENSIONS, IN INCHES.						
			Nominal D	B	W	M	N	F	R
G36	300.0	36 $\frac{23}{32}$	36.72	16.655	.945	1.353	2.007	7.855	.95
	280.0	36 $\frac{1}{2}$	36.50	16.600	.890	1.243	1.897	7.855	.95
	260.0	36 $\frac{1}{4}$	36.24	16.555	.845	1.113	1.767	7.855	.95
	250.0	36 $\frac{1}{8}$	36.12	16.530	.820	1.053	1.707	7.855	.95
	240.0	36	36.00	16.500	.790	.993	1.647	7.855	.95
	230.0	35 $\frac{7}{8}$	35.88	16.475	.765	.933	1.587	7.855	.95

BETHLEHEM GIRDER BEAMS.

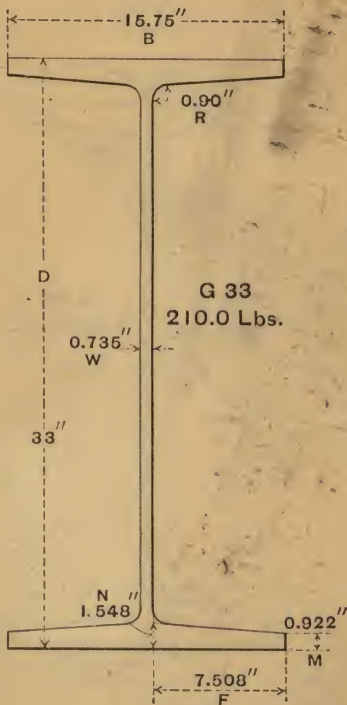

Section Number.	Weight per Foot, Pounds.	Nominal Depth of Beam, Inches.	DIMENSIONS, IN INCHES.						
			Nominal D	B	W	M	N	F	R
G33	260.0	33 $\frac{5}{8}$	33.63	15.890	.875	1.237	1.863	7.508	.90
	245.0	33 $\frac{7}{16}$	33.44	15.850	.835	1.142	1.768	7.508	.90
	230.0	33 $\frac{1}{4}$	33.25	15.810	.795	1.047	1.673	7.508	.90
	220.0	33 $\frac{1}{8}$	33.12	15.780	.765	.982	1.608	7.508	.90
	210.0	33	33.00	15.750	.735	.922	1.548	7.508	.90
	200.0	32 $\frac{7}{8}$	32.88	15.715	.700	.862	1.488	7.508	.90

BETHLEHEM GIRDER BEAMS.

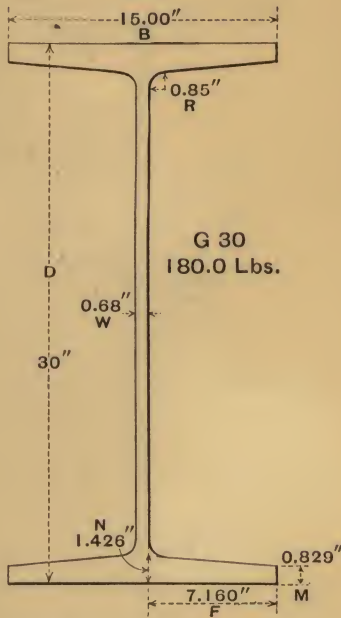

Section Number.	Weight per Foot, Pounds.	Nominal Depth of Beam, Inches.	DIMENSIONS, IN INCHES.						
			Nominal D	B	W	M	N	F	R
G30	240.0	30 ³ / ₄	30.75	15.200	.880	1.204	1.801	7.160	.85
	220.0	30 ¹ / ₂	30.50	15.135	.815	1.079	1.676	7.160	.85
	200.0	30 ¹ / ₄	30.25	15.065	.745	.954	1.551	7.160	.85
	190.0	30 ¹ / ₈	30.12	15.030	.710	.889	1.486	7.160	.85
	180.0	30	30.00	15.000	.680	.829	1.426	7.160	.85
	173.0	29 ⁷ / ₈	29.88	14.980	.660	.769	1.366	7.160	.85

BETHLEHEM GIRDER BEAMS.

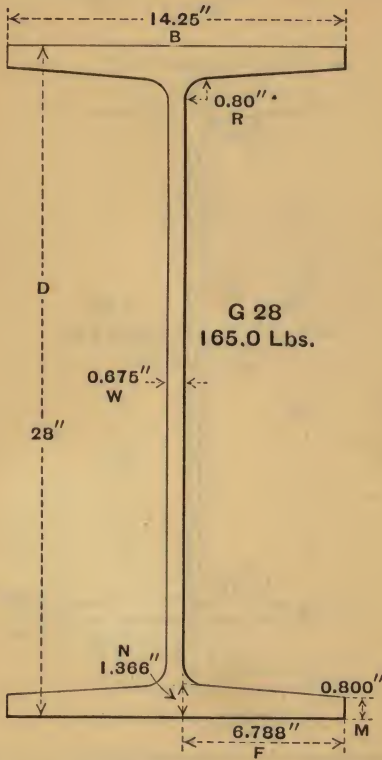

Section Number.	Weight per Foot, Pounds.	Nominal Depth of Beam, Inches.	DIMENSIONS, IN INCHES.						
			Nominal D	B	W	M	N	F	R
G28	186.0	28 ⁵ / ₁₆	28.31	14.305	.730	.955	1.521	6.788	.80
	175.0	28 ¹ / ₈	28.12	14.285	.710	.860	1.426	6.788	.80
	165.0	28	28.00	14.250	.675	.800	1.366	6.788	.80
	156.0	27 ⁷ / ₈	27.88	14.210	.635	.740	1.306	6.788	.80
	145.0	27 ³ / ₄	27.75	14.160	.585	.675	1.241	6.788	.80

BETHLEHEM GIRDER BEAMS.

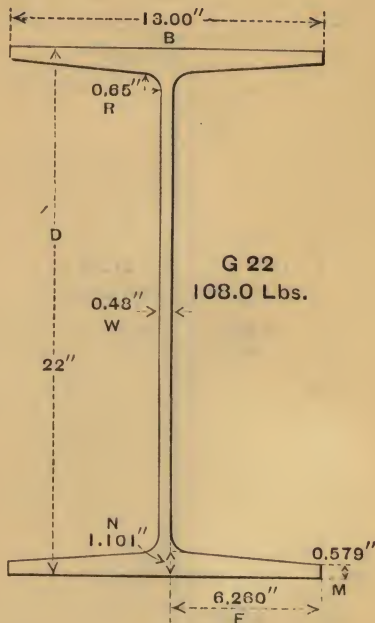

Section Number.	Weight per Foot, Pounds.	Nominal Depth of Beam, Inches.	DIMENSIONS, IN INCHES.						
			Nominal D	B	W	M	N	F	R
G22	132.0	22 $\frac{3}{8}$	22.38	13.095	.575	.769	1.291	6.260	.65
	124.0	22 $\frac{1}{4}$	22.25	13.065	.545	.704	1.226	6.260	.65
	116.0	22 $\frac{1}{8}$	22.12	13.030	.510	.639	1.161	6.260	.65
	108.0	22	22.00	13.000	.480	.579	1.101	6.260	.65
	101.0	21 $\frac{7}{8}$	21.88	12.970	.450	.519	1.041	6.260	.65

BETHLEHEM I BEAMS.

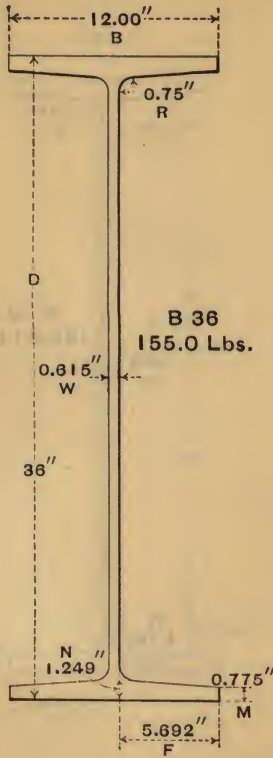

Section Number.	Weight per Foot, Pounds.	Nominal Depth of Beam, Inches.	DIMENSIONS, IN INCHES.						
			Nominal D	B	W	M	N	F	R
B36	190.0	36 ¹⁷ / ₃₂	36.52	12.111	.726	1.035	1.509	5.692	.75
	173.0	36 ¹ / ₄	36.25	12.065	.680	.900	1.374	5.692	.75
	164.0	36 ¹ / ₈	36.12	12.030	.645	.835	1.309	5.692	.75
	155.0	36	36.00	12.000	.615	.775	1.249	5.692	.75
	147.0	35 ²⁹ / ₃₂	35.90	11.968	.583	.725	1.199	5.692	.75

BETHLEHEM I BEAMS.

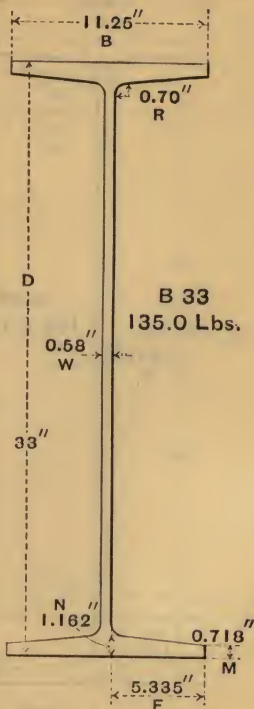

Section Number.	Weight per Foot, Pounds.	Nominal Depth of Beam, Inches.	DIMENSIONS, IN INCHES.						
			Nominal D	B	W	M	N	F	R
B33	165.0	33½	33.50	11.350	.680	.968	1.412	5.335	.70
	152.0	33⅝	33.27	11.312	.642	.853	1.297	5.335	.70
	143.0	33⅞	33.12	11.285	.615	.778	1.222	5.335	.70
	135.0	33	33.00	11.250	.580	.718	1.162	5.335	.70
	125.0	32⅞	32.89	11.205	.535	.663	1.107	5.335	.70

BETHLEHEM I BEAMS.

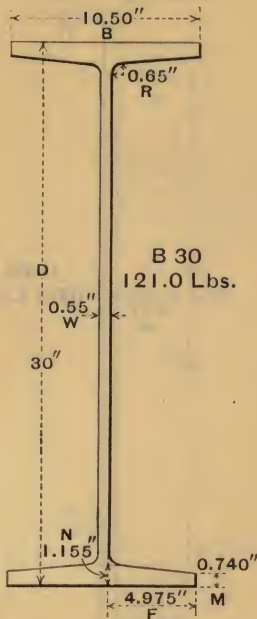

Section Number.	Weight per Foot, Pounds.	Nominal Depth of Beam, Inches.	DIMENSIONS, IN INCHES.						
			Nominal D	B	W	M	N	F	R
B30	163.0	30 ²¹ / ₃₂	30.65	10.68	.730	1.065	1.480	4.975	.65
	149.0	30 ⁷ / ₁₆	30.44	10.62	.670	.960	1.375	4.975	.65
	137.0	30 ¹ / ₄	30.25	10.57	.620	.865	1.280	4.975	.65
	129.0	30 ¹ / ₈	30.12	10.53	.580	.800	1.215	4.975	.65
	121.0	30	30.00	10.50	.550	.740	1.155	4.975	.65
	115.0	29 ⁷ / ₈	29.88	10.48	.530	.680	1.095	4.975	.65
	110.0	29 ²⁵ / ₃₂	29.78	10.47	.520	.630	1.045	4.975	.65

BETHLEHEM I BEAMS.

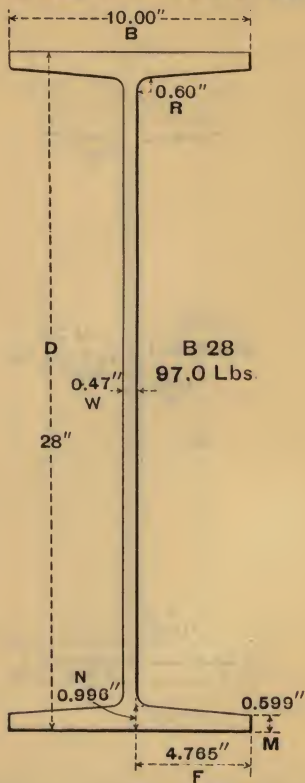

Section Number.	Weight per Foot, Pounds.	Nominal Depth of Beam, Inches.	DIMENSIONS, IN INCHES.						
			Nominal D	B	W	M	N	F	R
B28	133.0	28 $\frac{19}{32}$	28.59	10.160	.630	.894	1.291	4.765	.60
	119.0	28 $\frac{3}{8}$	28.38	10.095	.565	.789	1.186	4.765	.60
	112.0	28 $\frac{1}{4}$	28.25	10.065	.535	.724	1.121	4.765	.60
	104.0	28 $\frac{1}{8}$	28.12	10.030	.500	.659	1.056	4.765	.60
	97.0	28	28.00	10.000	.470	.599	.996	4.765	.60
	91.0	27 $\frac{7}{8}$	27.88	9.980	.450	.539	.936	4.765	.60
	85.0	27 $\frac{11}{16}$	27.69	9.980	.450	.444	.841	4.765	.60

BETHLEHEM I BEAMS.

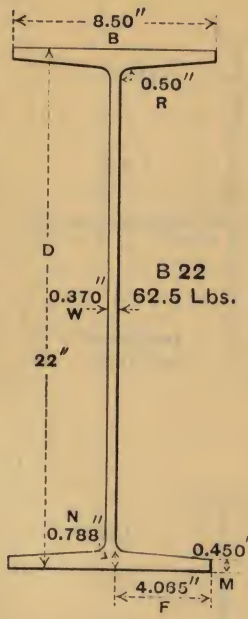

Section Number.	Weight per Foot, Pounds.	Nominal Depth of Beam, Inches.	DIMENSIONS, IN INCHES.						
			Nominal D	B	W	M	N	F	R
B22	73.0	22 1/4	22.25	8.545	.415	.575	.913	4.065	.50
	67.5	22 1/8	22.12	8.520	.390	.510	.848	4.065	.50
	62.5	22	22.00	8.500	.370	.450	.788	4.065	.50
	58.0	21 7/8	21.88	8.490	.360	.390	.728	4.065	.50
	54.5	21 3/4	21.75	8.490	.360	.325	.663	4.065	.50

BETHLEHEM H COLUMNS.

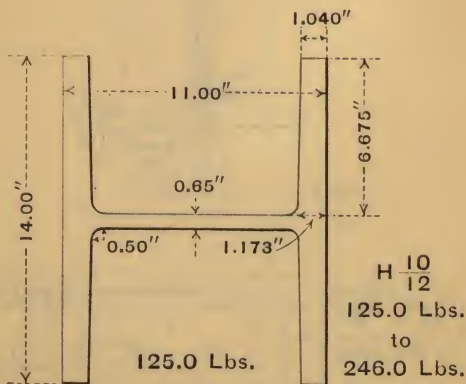
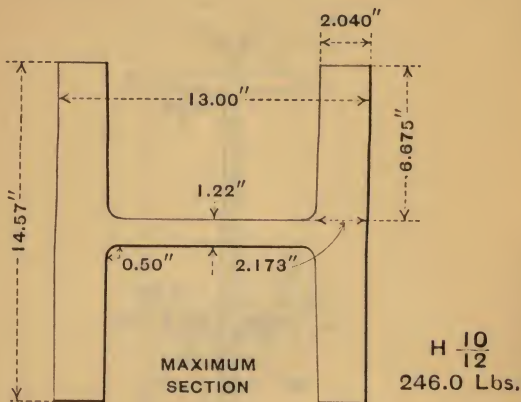

For intermediate weights and dimensions see page 28.

BETHLEHEM H COLUMNS.

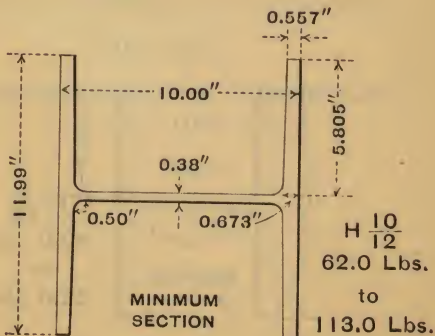
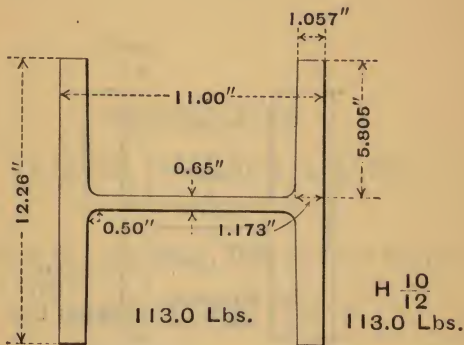

For intermediate weights and dimensions see page 28.

BETHLEHEM STANCHIONS.

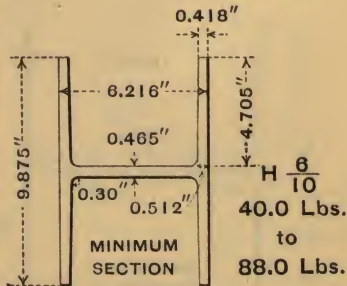
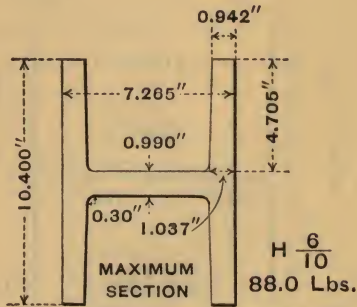

For intermediate weights and dimensions see page 30.

PROPERTIES,
TABLES OF SAFE LOADS
AND
OTHER USEFUL INFORMATION
RELATING TO
BETHLEHEM GIRDER BEAMS,
BETHLEHEM I BEAMS,
BETHLEHEM H COLUMNS,
AND
BETHLEHEM STANCHIONS.

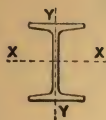

PROPERTIES OF
BETHLEHEM GIRDER BEAMS.

Section Number.	Nominal Depth of Beam, Inches.	Weight per Foot, Pounds.	Area of Section, Square Inches.	Thick-ness of Web, Inches.	Width of Flange, Inches.	AXIS X-X.		
						Moment of Inertia, Inches ⁴ .	Radius of Gyration, Inches.	Section Modulus, Inches ³ .
						I	r	S
G36	36 ²³ / ₃₂	300.0	88.12	.945	16.655	20,262	15.16	1103.6
	36 ¹ / ₂	280.0	82.45	.890	16.600	18,811	15.10	1030.8
	36 ¹ / ₄	260.0	76.50	.845	16.555	17,205	15.00	949.5
	36 ¹ / ₈	250.0	73.61	.820	16.530	16,457	14.95	911.2
	36	240.0	70.55	.790	16.500	15,696	14.92	872.0
	35 ⁷ / ₈	230.0	67.67	.765	16.475	14,960	14.87	833.9
G33	33 ⁵ / ₈	260.0	76.54	.875	15.890	14,868	13.94	884.2
	33 ⁷ / ₁₆	245.0	72.19	.835	15.850	13,895	13.87	831.0
	33 ¹ / ₄	230.0	67.85	.795	15.810	12,935	13.81	778.0
	33 ¹ / ₈	220.0	64.80	.765	15.780	12,278	13.77	741.4
	33	210.0	61.91	.735	15.750	11,671	13.73	707.3
	32 ⁷ / ₈	200.0	58.87	.700	15.715	11,055	13.70	672.4
G30	30 ³ / ₄	240.0	70.60	.880	15.200	11,423	12.72	742.9
	30 ¹ / ₂	220.0	64.82	.815	15.135	10,378	12.65	680.5
	30 ¹ / ₄	200.0	58.92	.745	15.065	9343.8	12.59	617.8
	30 ¹ / ₈	190.0	55.90	.710	15.030	8818.0	12.56	585.5
	30	180.0	53.20	.680	15.000	8343.1	12.52	556.2
	29 ⁷ / ₈	173.0	50.80	.660	14.980	7895.2	12.47	528.5

W = Safe Load, in pounds, uniformly distributed, including weight of beam.
L = Span, in feet.
M_t = Bending Moment of forces, in foot pounds.
f = Allowable Fiber Stress, in pounds per square inch.
S = Section Modulus about axis X-X.

PROPERTIES OF
BETHLEHEM GIRDER BEAMS.

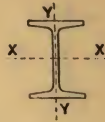

COEFFICIENTS OF STRENGTH.			Maximum Safe Shear on Web, in Pounds.	AXIS Y-Y.			Section Number.
For Fiber Stress of 18,000 Lbs. per Sq. In. For Quiescent Loads.	For Fiber Stress of 16,000 Lbs. per Sq. In. For Quiescent Loads.	For Fiber Stress of 12,000 Lbs. per Sq. In. For Moving Loads.		Moment of Inertia, Inches ⁴ .	Radius of Gyration, Inches.	Section Modulus, Inches ³ .	
C	C'	C''	I'	r'	S'		
13,240,000	11,770,000	8,829,000	334,800	1177.7	3.66	141.4	G36
12,370,000	10,990,000	8,246,000	302,400	1081.4	3.62	130.3	
11,390,000	10,130,000	7,596,000	275,700	973.7	3.57	117.6	
10,940,000	9,720,000	7,290,000	261,300	923.8	3.54	111.8	
10,460,000	9,301,000	6,976,000	244,400	873.5	3.52	105.9	
10,010,000	8,895,000	6,671,000	230,300	824.5	3.49	100.1	
10,610,000	9,432,000	7,074,000	285,900	939.8	3.50	118.3	G33
9,972,000	8,864,000	6,648,000	264,100	869.2	3.47	109.7	
9,337,000	8,299,000	6,224,000	242,500	799.6	3.43	101.2	
8,897,000	7,909,000	5,932,000	226,600	752.2	3.41	95.3	
8,488,000	7,545,000	5,659,000	211,000	708.5	3.38	90.0	
8,069,000	7,173,000	5,379,000	193,200	664.6	3.36	84.6	
8,915,000	7,925,000	5,944,000	277,300	799.2	3.36	105.2	G30
8,166,000	7,259,000	5,444,000	245,000	716.1	3.32	94.6	
7,413,000	6,590,000	4,942,000	210,900	634.2	3.28	84.2	
7,026,000	6,246,000	4,684,000	194,100	592.7	3.26	78.9	
6,674,000	5,933,000	4,450,000	179,800	555.1	3.23	74.0	
6,342,000	5,637,000	4,228,000	170,200	519.1	3.20	69.3	

C, C', and C'' = Coefficients given in the table.

$$W = \frac{C}{L}, \text{ or } \frac{C'}{L}, \text{ or } \frac{C''}{L}; M_f = \frac{C}{8}, \text{ or } \frac{C'}{8}, \text{ or } \frac{C''}{8}$$

$$C, C', \text{ or } C'' = WL = 8M_f = \frac{2}{3} tS$$



PROPERTIES OF
BETHLEHEM GIRDER BEAMS.

Section Number.	Nominal Depth of Beam, Inches.	Weight per Foot, Pounds.	Area of Section, Square Inches.	Thick-ness of Web, Inches.	Width of Flange, Inches.	AXIS X-X.		
						Moment of Inertia, Inches ⁴ .	Radius of Gyration, Inches.	Section Modulus, Inches ³ .
						I	r	S
G28	28 ⁵ / ₁₆	186.0	54.73	.730	14.305	7604.0	11.79	537.2
	28 ¹ / ₈	175.0	51.45	.710	14.285	7026.0	11.69	499.7
	28	165.0	48.75	.675	14.250	6624.6	11.66	473.2
	27 ⁷ / ₈	156.0	45.93	.635	14.210	6218.6	11.64	446.1
	27 ³ / ₄	145.0	42.69	.585	14.160	5772.3	11.63	416.0
G22	22 ³ / ₈	132.0	38.96	.575	13.095	3501.2	9.48	312.9
	22 ¹ / ₄	124.0	36.59	.545	13.065	3261.7	9.44	293.2
	22 ¹ / ₈	116.0	34.12	.510	13.030	3021.2	9.41	273.2
	22	108.0	31.89	.480	13.000	2804.3	9.38	254.9
	21 ⁷ / ₈	101.0	29.68	.450	12.970	2590.4	9.34	236.8

- W** = Safe Load, in pounds, uniformly distributed, including weight of beam.
L = Span, in feet.
M_f = Bending Moment of forces, in foot pounds.
f = Allowable Fiber Stress, in pounds per square inch.
S = Section Modulus about axis X-X.

PROPERTIES OF
BETHLEHEM GIRDER BEAMS.

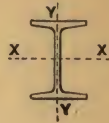

COEFFICIENTS OF STRENGTH.			Maximum Safe Shear on Web, in Pounds.	AXIS Y-Y.			Section Number.
For Fiber Stress of 18,000 Lbs. per Sq. In. For Quiescent Loads.	For Fiber Stress of 16,000 Lbs. per Sq. In. For Quiescent Loads.	For Fiber Stress of 12,000 Lbs. per Sq. In. For Moving Loads.		Moment of Inertia, Inches ⁴ .	Radius of Gyration, Inches.	Section Modulus, Inches ³ .	
C	C'	C''		I'	r'	S'	
6,446,000	5,730,000	4,298,000	199,400	539.7	3.14	75.5	G28
5,997,000	5,330,000	3,998,000	189,500	491.1	3.09	68.8	
5,678,000	5,047,000	3,785,000	173,900	458.3	3.07	64.3	
5,353,000	4,758,000	3,569,000	156,400	425.4	3.04	59.9	
4,992,000	4,438,000	3,328,000	135,100	389.8	3.02	55.1	
3,755,000	3,337,000	2,503,000	124,500	339.3	2.95	51.8	G22
3,518,000	3,127,000	2,345,000	113,700	312.6	2.92	47.9	
3,278,000	2,914,000	2,185,000	101,400	286.0	2.90	43.9	
3,059,000	2,719,000	2,039,000	91,000	261.9	2.87	40.3	
2,841,000	2,526,000	1,894,000	80,800	238.1	2.83	36.7	

C, C', and C'' = Coefficients given in the table.

$$W = \frac{C}{L}, \text{ or } \frac{C'}{L}, \text{ or } \frac{C''}{L}; M_f = \frac{C}{8}, \text{ or } \frac{C'}{8}, \text{ or } \frac{C''}{8}$$

$$C, \text{ or } C', \text{ or } C'' = WL = 8M_f = \frac{2}{3} fS$$

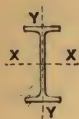

PROPERTIES OF
BETHLEHEM I BEAMS.

Section Number.	Nominal Depth of Beam, Inches.	Weight per Foot, Pounds.	Area of Section, Square Inches.	Thick-ness of Web, Inches.	Width of Flange, Inches.	AXIS X-X.		
						Moment of Inertia, Inches ⁴ .	Radius of Gyration, Inches.	Section Modulus, Inches ³ .
						I	r	S
B36	36 ¹⁷ / ₃₂	190.0	55.87	.726	12.111	12,049	14.68	659.9
	36 ¹ / ₄	173.0	50.94	.680	12.065	10,784	14.55	595.0
	36 ¹ / ₈	164.0	48.10	.645	12.030	10,133	14.51	561.1
	36	155.0	45.58	.615	12.000	9547.4	14.47	530.4
	35 ²⁹ / ₃₂	147.0	43.23	.583	11.968	9036.3	14.46	503.4
B33	33 ¹ / ₂	165.0	48.52	.680	11.350	8835.4	13.49	527.5
	33 ⁹ / ₃₂	152.0	44.65	.642	11.312	7991.4	13.38	480.4
	33 ¹ / ₈	143.0	42.05	.615	11.285	7442.2	13.30	449.4
	33	135.0	39.55	.580	11.250	6967.4	13.27	422.3
	32 ⁷ / ₈	125.0	36.83	.535	11.205	6498.2	13.28	395.1
B30	30 ²¹ / ₃₂	163.0	48.00	.730	10.680	7270.7	12.31	474.4
	30 ⁷ / ₁₆	149.0	43.93	.670	10.620	6606.6	12.26	434.1
	30 ¹ / ₄	137.0	40.40	.620	10.570	6026.7	12.21	398.5
	30 ¹ / ₈	129.0	37.82	.580	10.530	5622.7	12.19	373.4
	30	121.0	35.65	.550	10.500	5269.7	12.16	351.3
	29 ⁷ / ₈	115.0	33.80	.530	10.480	4942.9	12.09	330.8
	29 ²⁵ / ₃₂	110.0	32.45	.520	10.470	4687.7	12.02	314.8

W = Safe Load, in pounds, uniformly distributed, including weight of beam.

L = Span, in feet.

M_f = Bending Moment of forces, in foot pounds.

f = Allowable Fiber Stress, in pounds per square inch.

S = Section Modulus about axis X-X.

PROPERTIES OF
BETHLEHEM I BEAMS.



COEFFICIENTS OF STRENGTH.			Maximum Safe Shear on Web, in Pounds.	AXIS Y-Y.			Section Number.
For Fiber Stress of 18,000 Lbs. per Sq. In. For Quiescent Loads.	For Fiber Stress of 16,000 Lbs. per Sq. In. For Quiescent Loads.	For Fiber Stress of 12,000 Lbs. per Sq. In. For Moving Loads.		Moment of Inertia, Inches ⁴ .	Radius of Gyration, Inches.	Section Modulus, Inches ³ .	
C	C'	C''		I'	r'	S'	
7,918,000	7,039,000	5,279,000	209,300	344.9	2.48	57.0	B36
7,140,000	6,347,000	4,760,000	184,000	301.1	2.43	49.9	
6,733,000	5,985,000	4,489,000	165,600	279.4	2.41	46.5	
6,365,000	5,658,000	4,243,000	150,300	259.9	2.39	43.3	
6,041,000	5,370,000	4,027,000	134,500	243.3	2.37	40.7	
6,330,000	5,627,000	4,220,000	183,200	265.5	2.34	46.8	B33
5,765,000	5,124,000	3,843,000	163,700	234.9	2.29	41.5	
5,393,000	4,794,000	3,595,000	150,300	215.1	2.26	38.1	
5,067,000	4,504,000	3,378,000	133,700	198.7	2.24	35.3	
4,742,000	4,215,000	3,161,000	113,300	183.2	2.23	32.7	
5,693,000	5,061,000	3,795,000	204,100	239.8	2.24	44.9	B30
5,209,000	4,630,000	3,473,000	175,400	214.5	2.21	40.4	
4,782,000	4,250,000	3,188,000	152,100	192.6	2.18	36.4	
4,480,000	3,982,000	2,987,000	134,000	177.6	2.17	33.7	
4,216,000	3,747,000	2,811,000	120,700	164.3	2.15	31.3	
3,970,000	3,529,000	2,647,000	111,900	151.8	2.12	29.0	
3,778,000	3,358,000	2,519,000	107,500	141.8	2.09	27.1	

C, C', and C'' = Coefficients given in the table.

$$W = \frac{C}{L}, \text{ or } \frac{C'}{L}, \text{ or } \frac{C''}{L}; M_f = \frac{C}{8}, \text{ or } \frac{C'}{8}, \text{ or } \frac{C''}{8}$$

$$C, C', \text{ or } C'' = WL = 8M_f = \frac{2}{3} f S$$

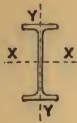

PROPERTIES OF
BETHLEHEM I BEAMS.

Section Number.	Nominal Depth of Beam, Inches.	Weight per Foot, Pounds.	Area of Section, Square Inches.	Thick-ness of Web, Inches.	Width of Flange, Inches.	AXIS X-X.		
						Moment of Inertia, Inches ⁴ .	Radius of Gyration, Inches.	Section Modulus, Inches ³ .
						I	r	S
B28	28 ¹⁹ / ₃₂	133.0	39.09	.630	10.160	5204.0	11.54	364.0
	28 ³ / ₈	119.0	35.11	.565	10.095	4647.4	11.50	327.5
	28 ¹ / ₄	112.0	32.95	.535	10.065	4328.0	11.46	306.4
	28 ¹ / ₈	104.0	30.66	.500	10.030	4003.3	11.43	284.7
	28	97.0	28.61	.470	10.000	3711.5	11.39	265.1
	27 ⁷ / ₈	91.0	26.86	.450	9.980	3441.1	11.32	246.9
	27 ¹¹ / ₁₆	85.0	24.96	.450	9.980	3075.2	11.10	222.1
B22	22 ¹ / ₄	73.0	21.51	.415	8.545	1796.7	9.14	161.5
	22 ¹ / ₈	67.5	19.84	.390	8.520	1637.5	9.08	148.1
	22	62.5	18.38	.370	8.500	1495.4	9.02	135.9
	21 ⁷ / ₈	58.0	17.14	.360	8.490	1363.9	8.92	124.7
	21 ³ / ₄	54.5	16.04	.360	8.490	1232.6	8.77	113.3

- W** = Safe Load, in pounds, uniformly distributed, including weight of beam.
L = Span, in feet.
M_f = Bending Moment of forces, in foot pounds.
f = Allowable Fiber Stress, in pounds per square inch.
S = Section Modulus about axis X-X.

PROPERTIES OF
BETHLEHEM I BEAMS.

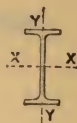

COEFFICIENTS OF STRENGTH.			Maximum Safe Shear on Web, in Pounds.	AXIS Y-Y.			Section Number.
For Fiber Stress of 18,000 Lbs. per Sq. In. For Quiescent Loads.	For Fiber Stress of 16,000 Lbs. per Sq. In. For Quiescent Loads.	For Fiber Stress of 12,000 Lbs. per Sq. In. For Moving Loads.		Moment of Inertia, Inches ⁴ .	Radius of Gyration, Inches.	Section Modulus, Inches ³ .	
C	C'	C''		I'	r'	S'	
4,369,000	3,883,000	2,912,000	155,100	175.3	2.12	34.5	B28
3,930,000	3,493,000	2,620,000	126,900	153.7	2.09	30.5	
3,677,000	3,268,000	2,451,000	114,100	141.2	2.07	28.1	
3,417,000	3,037,000	2,278,000	99,800	128.7	2.05	25.7	
3,181,000	2,828,000	2,121,000	87,900	117.4	2.03	23.5	
2,962,000	2,633,000	1,975,000	80,100	106.7	1.99	21.4	
2,665,000	2,369,000	1,777,000	79,600	91.0	1.91	18.2	B22
1,938,000	1,723,000	1,292,000	69,000	69.1	1.79	16.2	
1,777,000	1,579,000	1,184,000	60,800	61.8	1.76	14.5	
1,631,000	1,450,000	1,088,000	54,500	55.2	1.73	13.0	
1,496,000	1,330,000	997,400	51,300	48.9	1.69	11.5	
1,360,000	1,209,000	906,700	51,000	42.2	1.62	9.95	

C, C', and C'' = Coefficients given in the table.

$$W = \frac{C}{L}, \text{ or } \frac{C'}{L}, \text{ or } \frac{C''}{L}; \quad M_t = \frac{C}{8}, \text{ or } \frac{C'}{8}, \text{ or } \frac{C''}{8}$$

$$C, \text{ or } C', \text{ or } C'' = WL = 8M_t = \frac{2}{3} fS$$

DIMENSIONS AND PROPERTIES OF
BETHLEHEM 10'' H COLUMNS.

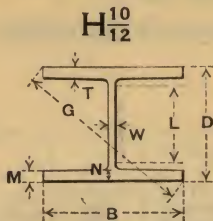

Section Number.	Weight per Foot, Pounds.	DIMENSIONS, IN INCHES.							
		D	B	W	T	M	N	G	L
	62.0	10	11.99	.38	.615	.557	.673	15 ⁵ / ₈	
	68.0	10 ¹ / ₈	12.03	.42	.675	.617	.733	15 ³ / ₄	
	75.0	10 ¹ / ₄	12.06	.45	.740	.682	.798	15 ¹³ / ₁₆	
	82.0	10 ³ / ₈	12.10	.49	.805	.747	.863	15 ¹⁵ / ₁₆	
	88.0	10 ¹ / ₂	12.14	.53	.865	.807	.923	16 ¹ / ₁₆	
	94.0	10 ⁵ / ₈	12.17	.56	.925	.867	.983	16 ¹ / ₈	
	100.0	10 ³ / ₄	12.20	.59	.990	.932	1.048	16 ¹ / ₄	
	107.0	10 ⁷ / ₈	12.23	.62	1.055	.997	1.113	16 ³ / ₈	
	113.0	11	12.26	.65	1.115	1.057	1.173	16 ¹ / ₂	
	125.0	11	14.00	.65	1.106	1.040	1.173	17 ¹³ / ₁₆	
	133.0	11 ¹ / ₈	14.04	.69	1.166	1.100	1.233	17 ¹⁵ / ₁₆	
	140.0	11 ¹ / ₄	14.08	.73	1.231	1.165	1.298	18	
	148.0	11 ³ / ₈	14.11	.76	1.296	1.230	1.363	18 ¹ / ₈	
	155.0	11 ¹ / ₂	14.15	.80	1.356	1.290	1.423	18 ¹ / ₄	
	162.0	11 ⁵ / ₈	14.19	.84	1.416	1.350	1.483	18 ⁵ / ₁₆	
	170.0	11 ³ / ₄	14.22	.87	1.481	1.415	1.548	18 ⁷ / ₁₆	
	177.0	11 ⁷ / ₈	14.25	.90	1.546	1.480	1.613	18 ⁹ / ₁₆	
	185.0	12	14.29	.94	1.606	1.540	1.673	18 ¹¹ / ₁₆	
	192.0	12 ¹ / ₈	14.32	.97	1.666	1.600	1.733	18 ³ / ₄	
	200.0	12 ¹ / ₄	14.36	1.01	1.731	1.665	1.798	18 ⁷ / ₈	
	208.0	12 ³ / ₈	14.40	1.05	1.796	1.730	1.863	19	
	215.0	12 ¹ / ₂	14.43	1.08	1.856	1.790	1.923	19 ¹ / ₁₆	
	222.0	12 ⁵ / ₈	14.46	1.11	1.916	1.850	1.983	19 ³ / ₁₆	
	230.0	12 ³ / ₄	14.50	1.15	1.981	1.915	2.048	19 ⁵ / ₁₆	
	238.0	12 ⁷ / ₈	14.53	1.18	2.046	1.980	2.113	19 ⁷ / ₁₆	
	246.0	13	14.57	1.22	2.106	2.040	2.173	19 ¹ / ₂	

H¹⁰/₁₂

L is constant = 7¹¹/₁₆

DIMENSIONS AND PROPERTIES OF
BETHLEHEM 10'' H COLUMNS.

H_{12}^{10}

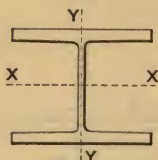

Weight per Foot, Pounds.	Area, Square Inches.	AXIS X-X.				AXIS Y-Y.			
		Moment of Inertia, Inches ⁴ .	Section Modulus, Inches ³ .	Radius of Gyration, Inches.	Bending Factor.	Moment of Inertia, Inches ⁴ .	Section Modulus, Inches ³ .	Radius of Gyration, Inches.	Bending Factor.
		I	S	r	k	I'	S'	r'	k'
62.0	18.29	350.1	70.0	4.38	.261	168.7	28.1	3.04	.650
68.0	20.13	390.0	77.1	4.40	.261	187.8	31.2	3.05	.645
75.0	22.00	433.2	84.5	4.44	.260	208.3	34.5	3.08	.637
82.0	23.98	478.6	92.2	4.47	.260	229.6	37.9	3.09	.632
88.0	25.86	522.1	99.4	4.49	.260	249.8	41.2	3.11	.628
94.0	27.63	565.7	106.5	4.52	.259	269.7	44.3	3.12	.623
100.0	29.54	613.9	114.2	4.56	.259	291.5	47.8	3.14	.618
107.0	31.45	663.5	122.0	4.59	.258	313.5	51.3	3.16	.613
113.0	33.25	710.8	129.2	4.62	.257	334.3	54.5	3.17	.610
125.0	36.89	801.4	145.7	4.66	.253	491.7	70.2	3.65	.525
133.0	39.02	857.4	154.2	4.69	.253	523.7	74.6	3.66	.523
140.0	41.29	919.2	163.4	4.72	.253	558.5	79.3	3.68	.521
148.0	43.46	981.5	172.5	4.75	.252	592.6	84.0	3.69	.517
155.0	45.62	1042.0	181.2	4.78	.252	626.0	88.5	3.70	.516
162.0	47.78	1103.9	190.0	4.81	.251	660.0	93.0	3.72	.514
170.0	49.98	1170.9	199.3	4.84	.251	695.5	97.8	3.73	.511
177.0	52.18	1239.6	208.7	4.87	.250	731.3	102.6	3.74	.508
185.0	54.37	1306.3	217.7	4.90	.250	766.8	107.3	3.76	.507
192.0	56.45	1373.2	226.6	4.93	.249	801.1	111.9	3.77	.505
200.0	58.80	1448.4	236.5	4.96	.249	840.0	117.0	3.78	.503
208.0	61.17	1525.5	246.4	4.99	.248	879.6	122.2	3.79	.501
215.0	63.27	1597.2	255.6	5.02	.248	915.2	126.9	3.80	.499
222.0	65.38	1670.5	264.7	5.05	.247	951.3	131.6	3.81	.497
230.0	67.77	1753.1	275.0	5.09	.246	992.4	136.9	3.83	.495
238.0	70.04	1835.8	285.1	5.12	.246	1031.9	142.0	3.84	.493
246.0	72.30	1916.1	294.8	5.15	.245	1071.6	147.1	3.85	.492

DIMENSIONS AND PROPERTIES OF
BETHLEHEM STANCHIONS.

$H \frac{6}{10}$

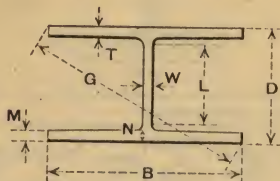

Section Number.	Weight per Foot, Pounds.	DIMENSIONS, IN INCHES.							
		D	B	W	T	M	N	G	L
$H \frac{6}{10}$	40.0	6.216	9.875	.465	.465	.418	.512	$11\frac{11}{16}$	L is constant = $4\frac{5}{8}$
	46.0	6.356	9.944	.534	.535	.488	.582	$11\frac{13}{16}$	
	53.0	6.512	10.022	.612	.613	.566	.660	$11\frac{15}{16}$	
	60.0	6.666	10.099	.689	.690	.643	.737	$12\frac{1}{8}$	
	67.0	6.818	10.175	.765	.766	.719	.813	$12\frac{1}{4}$	
	73.0	6.946	10.241	.831	.830	.783	.877	$12\frac{3}{8}$	
	80.0	7.096	10.315	.905	.905	.858	.952	$12\frac{1}{2}$	
	88.0	7.265	10.400	.990	.989	.942	1.037	$12\frac{11}{16}$	

DIMENSIONS AND PROPERTIES OF
BETHLEHEM STANCHIONS.

H_{10}^6

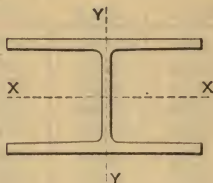

Weight per Foot, Pounds.	Area, Square Inches.	AXIS X-X.				AXIS Y-Y.			
		Moment of Inertia, Inches ⁴ . I	Section Modu- lus, Inches ³ . S	Radius ^s of Gyra- tion, Inches. r	Bend- ing Factor. k	Moment of Inertia, Inches ⁴ . I'	Section Modu- lus, Inches ³ . S'	Radius of Gyra- tion, Inches. r'	Bend- ing Factor. k'
40.0	11.71	82.3	26.5	2.65	.443	71.1	14.4	2.46	.814
46.0	13.54	97.4	30.6	2.68	.442	84.1	16.9	2.49	.800
53.0	15.59	115.2	35.4	2.72	.441	99.3	19.8	2.52	.787
60.0	17.65	133.9	40.2	2.75	.439	114.9	22.7	2.55	.776
67.0	19.70	153.3	45.0	2.79	.438	130.9	25.7	2.58	.766
73.0	21.47	170.6	49.1	2.82	.437	145.0	28.3	2.60	.758
80.0	23.53	191.7	54.0	2.85	.435	162.0	31.4	2.62	.749
88.0	25.89	216.9	59.7	2.89	.433	182.0	35.0	2.65	.740

SAFE LOADS UNIFORMLY DISTRIBUTED FOR
BETHLEHEM GIRDER BEAMS,
 IN THOUSANDS OF POUNDS.

MAXIMUM FIBER STRESS, 18,000 POUNDS PER SQUARE INCH.

BEAMS SECURED AGAINST YIELDING SIDEWAYS.

Span in Feet.	G36					
	36 $\frac{2}{3}$ "	36 $\frac{1}{2}$ "	36 $\frac{1}{4}$ "	36 $\frac{1}{8}$ "	36"	35 $\frac{7}{8}$ "
	300 Lbs.	280 Lbs.	260 Lbs.	250 Lbs.	240 Lbs.	230 Lbs.
	669.6					
20	662.0	604.8	551.5	522.6		
21	630.5	589.0	542.4	520.5	488.7	460.5
22	601.8	562.3	517.7	496.8	475.5	455.0
23	575.7	537.8	495.2	475.2	454.8	435.2
24	551.7	515.4	474.6	455.4	435.8	417.1
25	529.6	494.8	455.6	437.2	418.4	400.4
26	509.2	475.8	438.1	420.4	402.3	385.0
27	490.4	458.1	421.9	404.8	387.4	370.7
28	472.9	441.8	406.8	390.4	373.6	357.5
29	456.6	426.6	392.8	376.9	360.7	345.2
30	441.3	412.3	379.7	364.3	348.7	333.7
31	427.1	399.0	367.4	352.6	337.4	322.9
32	413.8	386.6	355.9	341.6	326.9	312.8
33	401.2	374.8	345.2	331.2	317.0	303.3
34	389.4	363.8	335.0	321.5	307.6	294.4
35	378.3	353.4	325.4	312.3	298.9	286.0
36	367.8	343.6	316.4	303.6	290.6	278.1
37	357.8	334.3	307.8	295.4	282.7	270.5
38	348.4	325.5	299.7	287.6	275.3	263.4
39	339.5	317.2	292.1	280.3	268.2	256.7
40	331.0	309.3	284.8	273.3	261.5	250.3
41	322.9	301.7	277.8	266.6	255.1	244.1
42	315.2	294.5	271.2	260.2	249.0	238.3
43	307.9	287.7	264.9	254.2	243.3	232.8
44	300.9	281.1	258.9	248.4	237.7	227.5
45	294.2	274.9	253.1	242.9	232.4	222.4
46	287.8	268.9	247.6	237.6	227.4	217.6
47	281.7	263.2	242.3	232.6	222.6	213.0
48	275.8	257.7	237.3	227.7	217.9	208.5
49	270.2	252.4	232.4	223.1	213.5	204.3
50	264.8	247.4	227.8	218.6	209.2	200.2
51	259.6	242.5	223.3	214.3	205.1	196.3
52	254.6	237.9	219.0	210.2	201.2	192.5
53	249.8	233.4	214.9	206.2	197.4	188.9
54	245.2	229.1	210.9	202.4	193.7	185.4

Safe loads given include weight of beam.

Greatest safe loads limited by web shear or buckling are given above the heavy line.

SAFE LOADS UNIFORMLY DISTRIBUTED FOR
BETHLEHEM GIRDER BEAMS,
 IN THOUSANDS OF POUNDS.

MAXIMUM FIBER STRESS, 18,000 POUNDS PER SQUARE INCH.

BEAMS SECURED AGAINST YIELDING SIDEWAYS.

Span in Feet.	G33					
	33 $\frac{5}{8}$ "	33 $\frac{1}{2}$ "	33 $\frac{3}{4}$ "	33 $\frac{1}{2}$ "	33"	32 $\frac{7}{8}$ "
	260 Lbs.	245 Lbs.	230 Lbs.	220 Lbs.	210 Lbs.	200 Lbs.
	571.9	528.1				
19	558.4	524.8	485.0	453.2		
20	530.5	498.6	466.9	444.9	422.0	386.4
21	505.2	474.9	444.6	423.7	404.2	384.2
22	482.3	453.3	424.4	404.4	385.8	366.8
23	461.3	433.6	406.0	386.8	369.0	350.8
24	442.1	415.5	389.0	370.7	353.7	336.2
25	424.4	398.9	373.5	355.9	339.5	322.8
26	408.1	383.5	359.1	342.2	326.5	310.3
27	393.0	369.3	345.8	329.5	314.4	298.9
28	378.9	356.1	333.5	317.8	303.1	288.2
29	365.9	343.9	322.0	306.8	292.7	278.2
30	353.7	332.4	311.2	296.6	282.9	269.0
31	342.3	321.7	301.2	287.0	273.8	260.3
32	331.6	311.6	291.8	278.0	265.3	252.2
33	321.5	302.2	282.9	269.6	257.2	244.5
34	312.1	293.3	274.6	261.7	249.6	237.3
35	303.1	284.9	266.8	254.2	242.5	230.5
36	294.7	277.0	259.4	247.1	235.8	224.1
37	286.8	269.5	252.4	240.5	229.4	218.1
38	279.2	262.4	245.7	234.1	223.4	212.3
39	272.1	255.7	239.4	228.1	217.6	206.9
40	265.3	249.3	233.4	222.4	212.2	201.7
41	258.8	243.2	227.7	217.0	207.0	196.8
42	252.6	237.4	222.3	211.8	202.1	192.1
43	246.7	231.9	217.1	206.9	197.4	187.7
44	241.1	226.6	212.2	202.2	192.9	183.4
45	235.8	221.6	207.5	197.7	188.6	179.3
46	230.7	216.8	203.0	193.4	184.5	175.4
47	225.7	212.2	198.7	189.3	180.6	171.7
48	221.0	207.8	194.5	185.4	176.8	168.1
49	216.5	203.5	190.6	181.6	173.2	164.7
50	212.2	199.4	186.7	177.9	169.8	161.4
51	208.0	195.5	183.1	174.5	166.4	158.2
52	204.0	191.8	179.6	171.1	163.2	155.2
53	200.2	188.2	176.2	167.9	160.2	152.2
54	196.5	184.7	172.9	164.8	157.2	149.4

Safe loads given include weight of beam.

Greatest safe loads limited by web shear or buckling are given above the heavy line.

SAFE LOADS UNIFORMLY DISTRIBUTED FOR

BETHLEHEM GIRDER BEAMS,

IN THOUSANDS OF POUNDS.

MAXIMUM FIBER STRESS, 18,000 POUNDS PER SQUARE INCH.

BEAMS SECURED AGAINST YIELDING SIDEWAYS.

Span in Feet.	G 30					
	30¾"	30½"	30¼"	30⅜"	30"	29⅞"
	240 Lbs.	220 Lbs.	200 Lbs.	190 Lbs.	180 Lbs.	173 Lbs.
	554.7	489.9				
17	524.4	480.4	421.8			
18	495.3	453.7	411.8	388.2	359.7	340.4
19	469.2	429.8	390.2	369.8	351.3	333.8
20	445.8	408.3	370.7	351.3	333.7	317.1
21	424.5	388.9	353.0	334.6	317.8	302.0
22	405.2	371.2	337.0	319.4	303.4	288.3
23	387.6	355.0	322.3	305.5	290.2	275.7
24	371.5	340.3	308.9	292.8	278.1	264.3
25	356.6	326.6	296.5	281.0	267.0	253.7
26	342.9	314.1	285.1	270.2	256.7	243.9
27	330.2	302.4	274.6	260.2	247.2	234.9
28	318.4	291.6	264.8	250.9	238.4	226.5
29	307.4	281.6	255.6	242.3	230.1	218.7
30	297.2	272.2	247.1	234.2	222.5	211.4
31	287.6	263.4	239.1	226.6	215.3	204.6
32	278.6	255.2	231.7	219.6	208.6	198.2
33	270.2	247.5	224.6	212.9	202.2	192.2
34	262.2	240.2	218.0	206.6	196.3	186.5
35	254.7	233.3	211.8	200.7	190.7	181.2
36	247.6	226.8	205.9	195.2	185.4	176.2
37	240.9	220.7	200.4	189.9	180.4	171.4
38	234.6	214.9	195.1	184.9	175.6	166.9
39	228.6	209.4	190.1	180.2	171.1	162.6
40	222.9	204.2	185.3	175.7	166.9	158.6
41	217.4	199.2	180.8	171.4	162.8	154.7
42	212.3	194.4	176.5	167.3	158.9	151.0
43	207.3	189.9	172.4	163.4	155.2	147.5
44	202.6	185.6	168.5	159.7	151.7	144.1
45	198.1	181.5	164.7	156.1	148.3	140.9
46	193.8	177.5	161.2	152.7	145.1	137.9
47	189.7	173.7	157.7	149.5	142.0	134.9
48	185.7	170.1	154.4	146.4	139.0	132.1
49	181.9	166.7	151.3	143.4	136.2	129.4
50	178.3	163.3	148.3	140.5	133.5	126.8

Safe loads given include weight of beam.

Greatest safe loads limited by web shear or buckling are given above the heavy line.

SAFE LOADS UNIFORMLY DISTRIBUTED FOR

BETHLEHEM GIRDER BEAMS,

IN THOUSANDS OF POUNDS.

MAXIMUM FIBER STRESS, 18,000 POUNDS PER SQUARE INCH.

BEAMS SECURED AGAINST YIELDING SIDEWAYS.

Span in Feet.	G 28				
	28 $\frac{5}{16}$ "	28 $\frac{1}{8}$ "	28"	27 $\frac{7}{8}$ "	27 $\frac{3}{4}$ "
	186 Lbs.	175 Lbs.	165 Lbs.	156 Lbs.	145 Lbs.
		379.0			
16	398.7	374.8	347.8		
17	379.2	352.8	334.0	312.9	
18	358.1	333.2	315.4	297.4	270.2
19	339.3	315.6	298.8	281.7	262.7
20	322.3	299.9	283.9	267.7	249.6
21	307.0	285.6	270.4	254.9	237.7
22	293.0	272.6	258.1	243.3	226.9
23	280.3	260.7	246.9	232.7	217.0
24	268.6	249.9	236.6	223.0	208.0
25	257.8	239.9	227.1	214.1	199.7
26	247.9	230.7	218.4	205.9	192.0
27	238.7	222.1	210.3	198.3	184.9
28	230.2	214.2	202.8	191.2	178.3
29	222.3	206.8	195.8	184.6	172.1
30	214.9	199.9	189.3	178.4	166.4
31	207.9	193.5	183.2	172.7	161.0
32	201.4	187.4	177.4	167.3	156.0
33	195.3	181.7	172.1	162.2	151.3
34	189.6	176.4	167.0	157.4	146.8
35	184.2	171.3	162.2	152.9	142.6
36	179.1	166.6	157.7	148.7	138.7
37	174.2	162.1	153.5	144.7	134.9
38	169.6	157.8	149.4	140.9	131.4
39	165.3	153.8	145.6	137.3	128.0
40	161.2	149.9	142.0	133.8	124.8
41	157.2	146.3	138.5	130.6	121.8
42	153.5	142.8	135.2	127.5	118.9
43	149.9	139.5	132.0	124.5	116.1
44	146.5	136.3	129.0	121.7	113.5
45	143.2	133.3	126.2	119.0	110.9
46	140.1	130.4	123.4	116.4	108.5
47	137.1	127.6	120.8	113.9	106.2
48	134.3	124.9	118.3	111.5	104.0
49	131.6	122.4	115.9	109.2	101.9

Safe loads given include weight of beam.

Greatest safe loads limited by web shear or buckling are given above the heavy line.

SAFE LOADS UNIFORMLY DISTRIBUTED FOR
BETHLEHEM GIRDER BEAMS,
 IN THOUSANDS OF POUNDS.

MAXIMUM FIBER STRESS, 18,000 POUNDS PER SQUARE INCH.

BEAMS SECURED AGAINST YIELDING SIDWAYS.

Span in Feet.	G 22				
	22 $\frac{3}{8}$ "	22 $\frac{1}{4}$ "	22 $\frac{1}{2}$ "	22"	21 $\frac{7}{8}$ "
	132 Lbs.	124 Lbs.	116 Lbs.	108 Lbs.	101 Lbs.
	249.0	227.4			
16	234.7	219.9	202.7	181.9	
17	220.9	206.9	192.8	179.9	161.6
18	208.6	195.4	182.1	169.9	157.8
19	197.6	185.2	172.5	161.0	149.5
20	187.8	175.9	163.9	153.0	142.1
21	178.8	167.5	156.1	145.7	135.3
22	170.7	159.9	149.0	139.0	129.1
23	163.3	153.0	142.5	133.0	123.5
24	156.5	146.6	136.6	127.5	118.4
25	150.2	140.7	131.1	122.4	113.6
26	144.4	135.3	126.1	117.7	109.3
27	139.1	130.3	121.4	113.3	105.2
28	134.1	125.6	117.1	109.3	101.5
29	129.5	121.3	113.0	105.5	100.0
30	125.2	117.3	109.3	102.0	94.7
31	121.1	113.5	105.7	98.7	91.6
32	117.3	109.9	102.4	95.6	88.8
33	113.8	106.6	99.3	92.7	86.1
34	110.4	103.5	96.4	90.0	83.6
35	107.3	100.5	93.7	87.4	81.2
36	104.3	97.7	91.1	85.0	78.9
37	101.5	95.1	88.6	82.7	76.8
38	98.8	92.6	86.3	80.5	74.8
39	96.3	90.2	84.1	78.4	72.8
40	93.9	88.0	82.0	76.5	71.0
41	91.6	85.8	80.0	74.6	69.3
42	89.4	83.8	78.1	72.8	67.6
43	87.3	81.8	76.2	71.1	66.1
44	85.3	80.0	74.5	69.5	64.6
45	83.4	78.2	72.8	68.0	63.1

Safe loads given include weight of beam.

Greatest safe loads limited by web shear or buckling are given above the heavy line.

Safe loads below the dotted line produce deflections exceeding 1/360 of the span.

SAFE LOADS UNIFORMLY DISTRIBUTED FOR

**BETHLEHEM I BEAMS,
IN THOUSANDS OF POUNDS.**

MAXIMUM FIBER STRESS, 18,000 POUNDS PER SQUARE INCH.

BEAMS SECURED AGAINST YIELDING SIDEWAYS.

Span in Feet.	B 36				
	36 ¹ / ₂ "	36 ¹ / ₄ "	36 ³ / ₈ "	36"	35 ³ / ₂ "
	190 Lbs.	173 Lbs.	164 Lbs.	155 Lbs.	147 Lbs.
	418.7				
19	416.7	367.9			
20	395.9	357.0	331.2		
21	377.0	340.0	320.6	300.5	
22	359.9	324.5	306.0	289.3	269.0
23	344.3	310.4	292.7	276.7	262.7
24	329.9	297.5	280.5	265.2	251.7
25	316.7	285.6	269.3	254.6	241.6
26	304.5	274.6	259.0	244.8	232.3
27	293.3	264.4	249.4	235.7	223.7
28	282.8	255.0	240.5	227.3	215.8
29	273.0	246.2	232.2	219.5	208.3
30	263.9	238.0	224.4	212.2	201.4
31	255.4	230.3	217.2	205.3	194.9
32	247.4	223.1	210.4	198.9	188.8
33	239.9	216.4	204.0	192.9	183.1
34	232.9	210.0	198.0	187.2	177.7
35	226.2	204.0	192.4	181.9	172.6
36	219.9	198.3	187.0	176.8	167.8
37	214.0	193.0	182.0	172.0	163.3
38	208.4	187.9	177.2	167.5	159.0
39	203.0	183.1	172.6	163.2	154.9
40	198.0	178.5	168.3	159.1	151.0
41	193.1	174.1	164.2	155.2	147.3
42	188.5	170.0	160.3	151.5	143.8
43	184.1	166.0	156.6	148.0	140.5
44	180.0	162.3	153.0	144.7	137.3
45	176.0	158.7	149.6	141.4	134.2
46	172.1	155.2	146.4	138.4	131.3
47	168.5	151.9	143.3	135.4	128.5
48	165.0	148.8	140.3	132.6	125.9
49	161.6	145.7	137.4	129.9	123.3
50	158.4	142.8	134.7	127.3	120.8
51	155.3	140.0	132.0	124.8	118.5
52	152.3	137.3	129.5	122.4	116.2

Safe loads given include weight of beam.

Greatest safe loads limited by web shear or buckling are given above the heavy line.

SAFE LOADS UNIFORMLY DISTRIBUTED FOR

BETHLEHEM I BEAMS, IN THOUSANDS OF POUNDS.

MAXIMUM FIBER STRESS, 18,000 POUNDS PER SQUARE INCH.

BEAMS SECURED AGAINST YIELDING SIDEWAYS.

Span in Feet.	B 33				
	33½"	33¾"	33⅞"	33"	32⅞"
	165 Lbs.	152 Lbs.	143 Lbs.	135 Lbs.	125 Lbs.
	366.5	327.5	300.6		
18	351.7	320.3	299.6	267.4	
19	333.2	303.4	283.8	266.7	
20	316.5	288.3	269.7	253.4	226.7
21	301.4	274.5	256.8	241.3	225.8
22	287.7	262.0	245.1	230.3	215.5
23	275.2	250.7	234.5	220.3	206.2
24	263.8	240.2	224.7	211.1	197.6
25	253.2	230.6	215.7	202.7	189.7
26	243.5	221.7	207.4	194.9	182.4
27	234.4	213.5	199.7	187.7	175.6
28	226.1	205.9	192.6	181.0	169.4
29	218.3	198.8	186.0	174.7	163.5
30	211.0	192.2	179.8	168.9	158.1
31	204.2	186.0	174.0	163.5	153.0
32	197.8	180.2	168.5	158.3	148.2
33	191.8	174.7	163.4	153.5	143.7
34	186.2	169.6	158.6	149.0	139.5
35	180.9	164.7	154.1	144.8	135.5
36	175.8	160.1	149.8	140.8	131.7
37	171.1	155.8	145.8	137.0	128.2
38	166.6	151.7	141.9	133.3	124.8
39	162.3	147.8	138.3	129.9	121.6
40	158.3	144.1	134.8	126.7	118.6
41	154.4	140.6	131.5	123.6	115.7
42	150.7	137.3	128.4	120.6	112.9
43	147.2	134.1	125.4	117.8	110.3
44	143.9	131.0	122.6	115.2	107.8
45	140.7	128.1	119.8	112.6	105.4
46	137.6	125.3	117.2	110.2	103.1
47	134.7	122.7	114.7	107.8	100.9
48	131.9	120.1	112.4	105.6	98.8
49	129.2	117.7	110.1	103.4	96.8
50	126.6	115.3	107.9	101.3	94.8
51	124.1	113.0	105.8	99.4	93.0
52	121.7	110.9	103.7	97.4	91.2

Safe loads given include weight of beam.

Greatest safe loads limited by web shear or buckling are given above the heavy line.

SAFE LOADS UNIFORMLY DISTRIBUTED FOR

BETHLEHEM I BEAMS, IN THOUSANDS OF POUNDS.

MAXIMUM FIBER STRESS, 18,000 POUNDS PER SQUARE INCH.

BEAMS SECURED AGAINST YIELDING SIDWAYS.

Span in Feet.	B 30						
	30 ² $\frac{1}{2}$ "	30 $\frac{7}{16}$ "	30 $\frac{1}{4}$ "	30 $\frac{1}{8}$ "	30"	29 $\frac{7}{8}$ "	29 ² $\frac{5}{32}$ "
	163 Lbs.	149 Lbs.	137 Lbs.	129 Lbs.	121 Lbs.	115 Lbs.	110 Lbs.
	408.3						
14	406.6	350.9					
15	379.5	347.3	304.2				
16	355.8	325.6	298.9	268.1			
17	334.9	306.4	281.3	263.5	241.5	223.8	214.9
18	316.3	289.4	265.7	248.9	234.2	220.6	209.9
19	299.6	274.2	251.7	235.8	221.9	208.9	198.8
20	284.7	260.5	239.1	224.0	210.8	198.5	188.9
21	271.1	248.0	227.7	213.3	200.8	189.0	179.9
22	258.8	236.8	217.4	203.6	191.6	180.5	171.7
23	247.5	226.5	207.9	194.8	183.3	172.6	164.3
24	237.2	217.0	199.3	186.7	175.7	165.4	157.4
25	227.7	208.4	191.3	179.2	168.6	158.8	151.1
26	219.0	200.3	183.9	172.3	162.2	152.7	145.3
27	210.9	192.9	177.1	165.9	156.1	147.0	139.9
28	203.3	186.0	170.8	160.0	150.6	141.8	134.9
29	196.3	179.6	164.9	154.5	145.4	136.9	130.3
30	189.8	173.6	159.4	149.3	140.5	132.3	125.9
31	183.6	168.0	154.3	144.5	136.0	128.1	121.9
32	177.9	162.8	149.4	140.0	131.8	124.1	118.1
33	172.5	157.8	144.9	135.8	127.8	120.3	114.5
34	167.4	153.2	140.6	131.8	124.0	116.8	111.1
35	162.7	148.8	136.6	128.0	120.5	113.4	107.9
36	158.1	144.7	132.8	124.4	117.1	110.3	104.9
37	153.9	140.8	129.2	121.1	113.9	107.3	102.1
38	149.8	137.1	125.8	117.9	110.9	104.5	99.4
39	146.0	133.6	122.6	114.9	108.1	101.8	96.9
40	142.3	130.2	119.6	112.0	105.4	99.3	94.5
41	138.9	127.0	116.6	109.3	102.8	96.8	92.1
42	135.5	124.0	113.9	106.7	100.4	94.5	90.0
43	132.4	121.1	111.2	104.2	98.0	92.3	87.9
44	129.4	118.4	108.7	101.8	95.8	90.2	85.9
45	126.5	115.8	106.3	99.6	92.7	88.2	84.0
46	123.8	113.2	104.0	97.4	91.7	86.3	82.1
47	121.1	110.8	101.7	95.3	89.7	84.5	80.4
48	118.6	108.5	99.6	93.3	87.8	82.7	78.7
49	116.2	106.3	97.6	91.4	86.0	81.0	77.1
50	113.9	104.2	95.6	89.6	84.3	79.4	75.6

Safe loads given include weight of beam.

Greatest safe loads limited by web shear or buckling are given above the heavy line.

SAFE LOADS UNIFORMLY DISTRIBUTED FOR

BETHLEHEM I BEAMS, IN THOUSANDS OF POUNDS.

MAXIMUM FIBER STRESS, 18,000 POUNDS PER SQUARE INCH.
BEAMS SECURED AGAINST YIELDING SIDEWAYS.

Span in Feet.	B 28						
	28 ¹ / ₂ "	28 ³ / ₄ "	28 ¹ / ₄ "	28 ¹ / ₂ "	28"	27 ⁷ / ₈ "	27 ¹ / ₁₆ "
	133 Lbs.	119 Lbs.	112 Lbs.	104 Lbs.	97 Lbs.	91 Lbs.	85 Lbs.
	310.1						
15	291.3	253.7					
16	273.1	245.6	228.3				159.2
17	256.0	231.2	216.3				156.8
18	242.7	218.3	204.3	189.8			148.1
19	229.9	206.8	193.5	179.8	175.8	160.3	140.3
20	218.5	196.5	183.9	170.9	159.1	148.1	133.3
21	208.0	187.1	175.1	162.7	151.5	141.0	126.9
22	198.6	178.6	167.1	155.3	144.6	134.6	121.1
23	190.0	170.9	159.9	148.6	138.3	128.8	115.9
24	182.0	163.8	153.2	142.4	132.5	123.4	111.0
25	174.8	157.2	147.1	136.7	127.2	118.5	106.6
26	168.0	151.2	141.4	131.4	122.3	113.9	102.5
27	161.8	145.6	136.2	126.6	117.8	109.7	98.7
28	156.0	140.4	131.3	122.0	113.6	105.8	95.2
29	150.7	135.5	126.8	117.8	109.7	102.1	91.9
30	145.6	131.0	122.6	113.9	106.0	98.7	88.8
31	140.9	126.8	118.6	110.2	102.6	95.5	86.0
32	136.5	122.8	114.9	106.8	99.4	92.6	83.3
33	132.4	119.1	111.4	103.5	96.4	89.8	80.8
34	128.5	115.6	108.1	100.5	93.6	87.1	78.4
35	124.8	112.3	105.1	97.6	90.9	84.6	76.1
36	121.4	109.2	102.1	94.9	88.4	82.3	74.0
37	118.1	106.2	99.4	92.4	86.0	80.1	72.0
38	115.0	103.4	96.8	89.9	83.7	77.9	70.1
39	112.0	100.8	94.3	87.6	81.6	75.9	68.3
40	109.2	98.3	91.9	85.4	79.5	74.1	66.6
41	106.6	95.9	89.7	83.3	77.6	72.2	65.0
42	104.0	93.6	87.5	81.4	75.7	70.5	63.5
43	101.6	91.4	85.5	79.5	74.0	68.9	62.0
44	99.3	89.3	83.6	77.7	72.3	67.3	60.6
45	97.1	87.3	81.7	75.9	70.7	65.8	59.2
46	95.0	85.4	79.9	74.3	69.2	64.4	57.9
47	93.0	83.6	78.2	72.7	67.7	63.0	56.7
48	91.0	81.9	76.6	71.2	66.3	61.7	55.5
49	89.2	80.2	75.0	69.7	64.9	60.4	54.4
50	87.4	78.6	73.5	68.3	63.6	59.2	53.3

Safe loads given include weight of beam.

Greatest safe loads limited by web shear or buckling are given above the heavy line.

Safe loads below the dotted line produce deflections exceeding 1/360 of the span.

SAFE LOADS UNIFORMLY DISTRIBUTED FOR

BETHLEHEM I BEAMS,

IN THOUSANDS OF POUNDS.

MAXIMUM FIBER STRESS, 18,000 POUNDS PER SQUARE INCH.

BEAMS SECURED AGAINST YIELDING SIDWAYS.

Span in Feet.	B 22				
	22 $\frac{1}{4}$ "	22 $\frac{1}{8}$ "	22"	21 $\frac{7}{8}$ "	21 $\frac{3}{4}$ "
	73 Lbs.	67.5 Lbs.	62.5 Lbs.	58 Lbs.	54.5 Lbs.
					102.0
14	138.0	121.7	109.0	102.6	97.1
15	129.2	118.5	108.7	99.7	90.7
16	121.1	111.1	101.9	93.5	85.0
17	114.0	104.5	95.9	88.0	80.0
18	107.7	98.7	90.6	83.1	75.6
19	102.0	93.5	85.8	78.7	71.6
20	96.9	88.9	81.6	74.8	68.0
21	92.3	84.6	77.7	71.2	64.8
22	88.1	80.8	74.1	68.0	61.8
23	84.3	77.3	70.9	65.0	59.1
24	80.8	74.0	68.0	62.3	56.7
25	77.5	71.1	65.2	59.8	54.4
26	74.5	68.3	62.7	57.5	52.3
27	71.8	65.8	60.4	55.4	50.4
28	69.2	63.5	58.3	53.4	48.6
29	66.8	61.3	56.2	51.6	46.9
30	64.6	59.2	54.4	49.9	45.3
31	62.5	57.3	52.6	48.3	43.9
32	60.6	55.5	51.0	46.8	42.5
33	58.7	53.8	49.4	45.3	41.2
34	57.0	52.3	48.0	44.0	40.0
35	55.4	50.8	46.6	42.7	38.9
36	53.8	49.4	45.3	41.6	37.8
37	52.4	48.0	44.1	40.4	36.8
38	51.0	46.8	42.9	39.4	35.8
39	49.7	45.6	41.8	38.4	34.9
40	48.5	44.4	40.8	37.4	34.0
41	47.3	43.3	39.8	36.5	33.2
42	46.1	42.3	38.8	35.6	32.4
43	45.1	41.3	37.9	34.8	31.6
44	44.0	40.4	37.1	34.0	30.9
45	43.1	39.5	36.2	33.2	30.2
46	42.1	38.6	35.5	32.5	29.6
47	41.2	37.8	34.7	31.8	28.9

Safe loads given include weight of beam.

Greatest safe loads limited by web shear or buckling are given above the heavy line.

Safe loads below the dotted line produce deflections exceeding 1/360 of the span.

SAFE LOADS UNIFORMLY DISTRIBUTED FOR
BETHLEHEM GIRDER BEAMS,
 IN THOUSANDS OF POUNDS.

MAXIMUM FIBER STRESS, 16,000 POUNDS PER SQUARE INCH.

BEAMS SECURED AGAINST YIELDING SIDWAYS.

Span in Feet.	G36					
	36 ² / ₃₂ "	36 ¹ / ₂ "	36 ¹ / ₄ "	36 ³ / ₈ "	36"	35 ⁷ / ₈ "
	300 Lbs.	280 Lbs.	260 Lbs.	250 Lbs.	240 Lbs.	230 Lbs.
	595.2					
20	588.5	537.6	490.2	464.5		
21	560.5	523.3	482.4	462.9	434.4	409.4
22	535.0	499.6	460.5	441.8	422.8	404.3
23	511.7	477.8	440.0	422.6	404.4	386.7
24	490.4	457.9	422.1	405.0	387.5	370.6
25	470.8	439.6	405.2	388.8	372.0	355.8
26	452.7	422.7	389.6	373.8	357.7	342.1
27	435.9	407.0	375.2	360.0	344.5	329.4
28	420.4	392.5	361.8	347.1	332.2	317.7
29	405.9	379.0	349.3	335.2	320.7	306.7
30	392.3	366.3	337.7	324.0	310.0	296.5
31	379.7	354.5	326.8	313.5	300.0	286.9
32	367.8	343.4	316.6	303.8	290.7	278.0
33	356.7	333.0	307.0	294.5	281.8	269.5
34	346.2	323.2	297.9	285.9	273.6	261.6
35	336.3	314.0	289.4	277.7	265.7	254.1
36	326.9	305.3	281.4	270.0	258.4	247.1
37	318.1	297.0	273.8	262.7	251.4	240.4
38	309.7	289.2	266.6	255.8	244.8	234.1
39	301.8	281.8	259.7	249.2	238.5	228.1
40	294.3	274.8	253.3	243.0	232.5	222.4
41	287.1	268.1	247.1	237.1	226.9	217.0
42	280.2	261.7	241.2	231.4	221.5	211.8
43	273.7	255.6	235.6	226.0	216.3	206.9
44	267.5	249.8	230.2	220.9	211.4	202.2
45	261.6	244.2	225.1	216.0	206.7	197.7
46	255.9	238.9	220.2	211.3	202.2	193.4
47	250.4	233.8	215.5	206.8	197.9	189.3
48	245.2	229.0	211.0	202.5	193.8	185.3
49	240.2	224.3	206.7	198.4	189.8	181.5
50	235.4	219.8	202.6	194.4	186.0	177.9
51	230.8	215.5	198.6	190.6	182.4	174.4
52	226.3	211.4	194.8	186.9	178.9	171.1
53	222.1	207.4	191.1	183.4	175.5	167.8
54	218.0	203.5	187.6	180.0	172.2	164.7

Safe loads given include weight of beam.

Greatest safe loads limited by web shear or buckling are given above the heavy line.

SAFE LOADS UNIFORMLY DISTRIBUTED FOR
BETHLEHEM GIRDER BEAMS,
 IN THOUSANDS OF POUNDS.

MAXIMUM FIBER STRESS, 16,000 POUNDS PER SQUARE INCH.

BEAMS SECURED AGAINST YIELDING SIDEWAYS.

Span in Feet.	G33					
	33 $\frac{3}{4}$ "	33 $\frac{1}{2}$ "	33 $\frac{1}{4}$ "	33 $\frac{1}{8}$ "	33"	32 $\frac{7}{8}$ "
	260 Lbs.	245 Lbs.	230 Lbs.	220 Lbs.	210 Lbs.	200 Lbs.
	508.3	469.4				
19	496.4	466.5	431.1	402.9		
20	471.6	443.2	415.0	395.5	375.1	343.4
21	449.1	422.1	395.2	376.6	359.3	341.6
22	428.7	402.9	377.2	359.5	343.0	326.0
23	410.1	385.4	360.8	343.9	328.0	311.9
24	393.0	369.3	345.8	329.5	314.4	298.9
25	377.3	354.6	332.0	316.4	301.8	286.9
26	362.8	340.9	319.2	304.2	290.2	275.9
27	349.3	328.3	307.4	292.9	279.4	265.7
28	336.9	316.6	296.4	282.5	269.5	256.2
29	325.2	305.7	286.2	272.7	260.2	247.3
30	314.4	295.5	276.6	263.6	251.5	239.1
31	304.3	285.9	267.7	255.1	243.4	231.4
32	294.8	277.0	259.3	247.2	235.8	224.2
33	285.8	268.6	251.5	239.7	228.6	217.4
34	277.4	260.7	244.1	232.6	221.9	211.0
35	269.5	253.3	237.1	226.0	215.6	204.9
36	262.0	246.2	230.5	219.7	209.6	199.3
37	254.9	239.6	224.3	213.8	203.9	193.9
38	248.2	233.3	218.4	208.1	198.6	188.8
39	241.8	227.3	212.8	202.8	193.5	183.9
40	235.8	221.6	207.5	197.7	188.6	179.3
41	230.0	216.2	202.4	192.9	184.0	175.0
42	224.6	211.0	197.6	188.3	179.6	170.8
43	219.3	206.1	193.0	183.9	175.5	166.8
44	214.4	201.5	188.6	179.8	171.5	163.0
45	209.6	197.0	184.4	175.8	167.7	159.4
46	205.0	192.7	180.4	171.9	164.0	155.9
47	200.7	188.6	176.6	168.3	160.5	152.6
48	196.5	184.7	172.9	164.8	157.2	149.4
49	192.5	180.9	169.4	161.4	154.0	146.4
50	188.6	177.3	166.0	158.2	150.9	143.5
51	184.9	173.8	162.7	155.1	147.9	140.6
52	181.4	170.5	159.6	152.1	145.1	137.9
53	178.0	167.2	156.6	149.2	142.4	135.3
54	174.7	164.1	153.7	146.5	139.7	132.8

Safe loads given include weight of beam.

Greatest safe-loads limited by web shear or buckling are given above the heavy line.

SAFE LOADS UNIFORMLY DISTRIBUTED FOR
BETHLEHEM GIRDER BEAMS,
 IN THOUSANDS OF POUNDS.

MAXIMUM FIBER STRESS, 16,000 POUNDS PER SQUARE INCH.
 BEAMS SECURED AGAINST YIELDING SIDEWAYS.

Span in Feet.	G 30					
	30¾"	30½"	30¼"	30⅜"	30"	29⅞"
	240 Lbs.	220 Lbs.	200 Lbs.	190 Lbs.	180 Lbs.	173 Lbs.
	493.0	435.5				
17	466.2	427.0	374.9			
18	440.3	403.3	366.1	345.1	319.7	302.6
19	417.1	382.1	346.8	328.7	312.3	296.7
20	396.3	363.0	329.5	312.3	296.7	281.9
21	377.4	345.7	313.8	297.4	282.5	268.4
22	360.2	330.0	299.5	283.9	269.7	256.2
23	344.6	315.6	286.5	271.6	258.0	245.1
24	330.2	302.5	274.6	260.3	247.2	234.9
25	317.0	290.4	263.6	249.8	237.3	225.5
26	304.8	279.2	253.5	240.2	228.2	216.8
27	293.5	268.9	244.1	231.3	219.7	208.8
28	283.0	259.3	235.4	223.1	211.9	201.3
29	273.3	250.3	227.2	215.4	204.6	194.4
30	264.2	242.0	219.7	208.2	197.8	187.9
31	255.6	234.2	212.6	201.5	191.4	181.8
32	247.7	226.8	205.9	195.2	185.4	176.2
33	240.2	220.0	199.7	189.3	179.8	170.8
34	233.1	213.5	193.8	183.7	174.5	165.8
35	226.4	207.4	188.3	178.5	169.5	161.1
36	220.1	201.6	183.1	173.5	164.8	156.6
37	214.2	196.2	178.1	168.8	160.4	152.4
38	208.6	191.0	173.4	164.4	156.1	148.3
39	203.2	186.1	169.0	160.2	152.1	144.5
40	198.1	181.5	164.8	156.2	148.3	140.9
41	193.3	177.0	160.7	152.3	144.7	137.5
42	188.7	172.8	156.9	148.7	141.3	134.2
43	184.3	168.8	153.3	145.3	138.0	131.1
44	180.1	165.0	149.8	142.0	134.8	128.1
45	176.1	161.3	146.4	138.8	131.8	125.3
46	172.3	157.8	143.3	135.8	129.0	122.5
47	168.6	154.4	140.2	132.9	126.2	119.9
48	165.1	151.2	137.3	130.1	123.6	117.4
49	161.7	148.1	134.5	127.5	121.1	115.0
50	158.5	145.2	131.8	124.9	118.7	112.7

Safe loads given include weight of beam.

Greatest safe loads limited by web shear or buckling are given above the heavy line.

SAFE LOADS UNIFORMLY DISTRIBUTED FOR

BETHLEHEM GIRDER BEAMS, IN THOUSANDS OF POUNDS.

MAXIMUM FIBER STRESS, 16,000 POUNDS PER SQUARE INCH.
BEAMS SECURED AGAINST YIELDING SIDEWAYS.

Span in Feet.	G 28				
	28 $\frac{1}{2}$ "	28 $\frac{3}{8}$ "	28"	27 $\frac{7}{8}$ "	27 $\frac{3}{4}$ "
	186 Lbs.	175 Lbs.	165 Lbs.	156 Lbs.	145 Lbs.
		336.9			
16	354.4	333.1	309.2		
17	337.1	313.5	296.9	278.1	
18	318.3	296.1	280.4	264.3	240.2
19	301.6	280.5	265.6	250.4	233.6
20	286.5	266.5	252.4	237.9	221.9
21	272.9	253.8	240.3	226.6	211.3
22	260.5	242.3	229.4	216.3	201.7
23	249.1	231.7	219.4	206.9	193.0
24	238.8	222.1	210.3	198.3	184.9
25	229.2	213.2	201.9	190.3	177.5
26	220.4	205.0	194.1	183.0	170.7
27	212.2	197.4	186.9	176.2	164.4
28	204.6	190.4	180.3	169.9	158.5
29	197.6	183.8	174.0	164.1	153.0
30	191.0	177.7	168.2	158.6	147.9
31	184.8	171.9	162.8	153.5	143.2
32	179.1	166.6	157.7	148.7	138.7
33	173.6	161.5	152.9	144.2	134.5
34	168.5	156.8	148.4	139.9	130.5
35	163.7	152.3	144.2	135.9	126.8
36	159.2	148.1	140.2	132.2	123.3
37	154.9	144.1	136.4	128.6	119.9
38	150.8	140.3	132.8	125.2	116.8
39	146.9	136.7	129.4	122.0	113.8
40	143.3	133.3	126.2	119.0	111.0
41	139.8	130.0	123.1	116.0	108.2
42	136.4	126.9	120.2	113.3	105.7
43	133.3	124.0	117.4	110.7	103.2
44	130.2	121.1	114.7	108.1	100.9
45	127.3	118.4	112.2	105.7	98.6
46	124.6	115.9	109.7	103.4	96.5
47	121.9	113.4	107.4	101.2	94.4
48	119.4	111.0	105.2	99.1	92.5
49	116.9	108.8	103.0	97.1	90.6

Safe loads given include weight of beam.

Greatest safe loads limited by web shear or buckling are given above the heavy line.

SAFE LOADS UNIFORMLY DISTRIBUTED FOR

BETHLEHEM GIRDER BEAMS, IN THOUSANDS OF POUNDS.

MAXIMUM FIBER STRESS, 16,000 POUNDS PER SQUARE INCH.

BEAMS SECURED AGAINST YIELDING SIDEWAYS.

Span in Feet.	G 22				
	22 $\frac{3}{8}$ "	22 $\frac{1}{4}$ "	22 $\frac{1}{8}$ "	22"	21 $\frac{7}{8}$ "
	132 Lbs.	124 Lbs.	116 Lbs.	108 Lbs.	101 Lbs.
	221.4	202.1			
16	208.6	195.4	180.2	161.7	
17	196.3	183.9	171.4	159.9	143.6
18	185.4	173.7	161.9	151.1	140.3
19	175.6	164.6	153.4	143.1	132.9
20	166.9	156.4	145.7	136.0	126.3
21	158.9	148.9	138.8	129.5	120.3
22	151.7	142.1	132.5	123.6	114.8
23	145.1	136.0	126.7	118.2	109.8
24	139.0	130.3	121.4	113.3	105.3
25	133.5	125.1	116.6	108.8	101.0
26	128.3	120.3	112.1	104.6	97.2
27	123.6	115.8	107.9	100.7	93.6
28	119.2	111.7	104.1	97.1	90.2
29	115.1	107.8	100.5	93.8	87.1
30	111.2	104.2	97.1	90.6	84.2
31	107.6	100.9	94.0	87.7	81.5
32	104.3	97.7	91.1	85.0	78.9
33	101.1	94.8	88.3	82.4	76.5
34	98.1	92.0	85.7	80.0	74.3
35	95.3	89.3	83.3	77.7	72.2
36	92.7	86.9	80.9	75.5	70.2
37	90.2	84.5	78.8	73.5	68.3
38	87.8	82.3	76.7	71.6	66.5
39	85.6	80.2	74.7	69.7	64.8
40	83.4	78.2	72.9	68.0	63.2
41	81.4	76.3	71.1	66.3	61.6
42	79.5	74.5	69.4	64.7	60.1
43	77.6	72.7	67.8	63.2	58.7
44	75.8	71.1	66.2	61.8	57.4
45	74.2	69.5	64.8	60.4	56.1

Safe loads given include weight of beam.

Greatest safe loads limited by web shear or buckling are given above the heavy line.

Safe loads below the dotted line produce deflections exceeding 1/360 of the span.

SAFE LOADS UNIFORMLY DISTRIBUTED FOR

BETHLEHEM I BEAMS, IN THOUSANDS OF POUNDS.

MAXIMUM FIBER STRESS, 16,000 POUNDS PER SQUARE INCH.

BEAMS SECURED AGAINST YIELDING SIDWAYS.

Span in Feet.	B 36				
	36 ¹ / ₂ "	36 ³ / ₄ "	36 ⁵ / ₈ "	36"	35 ⁷ / ₈ "
	190 Lbs.	173 Lbs.	164 Lbs.	155 Lbs.	147 Lbs.
	372.2				
19	370.5	327.0			
20	352.0	317.4	294.4		
21	335.2	302.2	285.0	267.1	
22	320.0	288.5	272.0	257.2	239.1
23	306.0	276.0	260.2	246.0	233.5
24	293.3	264.5	249.4	235.8	223.8
25	281.6	253.9	239.4	226.3	214.8
26	270.7	244.1	230.2	217.6	206.5
27	260.7	235.1	221.7	209.6	198.9
28	251.4	226.7	213.8	202.1	191.8
29	242.7	218.9	206.4	195.1	185.2
30	234.6	211.6	199.5	188.6	179.0
31	227.1	204.7	193.1	182.5	173.2
32	220.0	198.3	187.0	176.8	167.8
33	213.3	192.3	181.4	171.5	162.7
34	207.0	186.7	176.0	166.4	157.9
35	201.1	181.3	171.0	161.7	153.4
36	195.5	176.3	166.3	157.2	149.2
37	190.2	171.5	161.8	152.9	145.1
38	185.2	167.0	157.5	148.9	141.3
39	180.5	162.7	153.5	145.1	137.7
40	176.0	158.7	149.6	141.5	134.3
41	171.7	154.8	146.0	138.0	131.0
42	167.6	151.1	142.5	134.7	127.9
43	163.7	147.6	139.2	131.6	124.9
44	160.0	144.3	136.0	128.6	122.1
45	156.4	141.0	133.0	125.7	119.3
46	153.0	138.0	130.1	123.0	116.7
47	149.8	135.0	127.3	120.4	114.3
48	146.7	132.2	124.7	117.9	111.9
49	143.7	129.5	122.1	115.5	109.6
50	140.8	126.9	119.7	113.2	107.4
51	138.0	124.5	117.4	110.9	105.3
52	135.4	122.1	115.1	108.8	103.3

Safe loads given include weight of beam.

Greatest safe loads limited by web shear or buckling are given above the heavy line.

SAFE LOADS UNIFORMLY DISTRIBUTED FOR

BETHLEHEM I BEAMS, IN THOUSANDS OF POUNDS.

MAXIMUM FIBER STRESS, 16,000 POUNDS PER SQUARE INCH.

BEAMS SECURED AGAINST YIELDING SIDEWAYS.

Span in Feet.	B 33				
	33½"	33¾"	33⅞"	33"	32⅞"
	165 Lbs.	152 Lbs.	143 Lbs.	135 Lbs.	125 Lbs.
	325.8	291.1	267.2		
18	312.6	284.7	266.3	237.7	
19	296.2	269.7	252.3	237.1	
20	281.4	256.2	239.7	225.2	201.5
21	268.0	244.0	228.3	214.5	200.7
22	255.8	232.9	217.9	204.7	191.6
23	244.7	222.8	208.4	195.8	183.3
24	234.5	213.5	199.8	187.7	175.6
25	225.1	205.0	191.8	180.2	168.6
26	216.4	197.1	184.4	173.2	162.1
27	208.4	189.8	177.6	166.8	156.1
28	201.0	183.0	171.2	160.9	150.5
29	194.0	176.7	165.3	155.3	145.3
30	187.6	170.8	159.8	150.1	140.5
31	181.5	165.3	154.7	145.3	136.0
32	175.8	160.1	149.8	140.8	131.7
33	170.5	155.3	145.3	136.5	127.7
34	165.5	150.7	141.0	132.5	124.0
35	160.8	146.4	137.0	128.7	120.4
36	156.3	142.3	133.2	125.1	117.1
37	152.1	138.5	129.6	121.7	113.9
38	148.1	134.8	126.2	118.5	110.9
39	144.3	131.4	122.9	115.5	108.1
40	140.7	128.1	119.9	112.6	105.4
41	137.2	125.0	116.9	109.9	102.8
42	134.0	122.0	114.1	107.2	100.4
43	130.9	119.2	111.5	104.7	98.0
44	127.9	116.5	109.0	102.4	95.8
45	125.0	113.9	106.5	100.1	93.7
46	122.3	111.4	104.2	97.9	91.6
47	119.7	109.0	102.0	95.8	89.7
48	117.2	106.8	99.9	93.8	87.8
49	114.8	104.6	97.8	91.9	86.0
50	112.5	102.5	95.9	90.1	84.3
51	110.3	100.5	94.0	88.3	82.7
52	108.2	98.5	92.2	86.6	81.1

Safe loads given include weight of beam.

Greatest safe loads limited by web shear or buckling are given above the heavy line.

SAFE LOADS UNIFORMLY DISTRIBUTED FOR

BETHLEHEM I BEAMS, IN THOUSANDS OF POUNDS.

MAXIMUM FIBER STRESS, 16,000 POUNDS PER SQUARE INCH.

BEAMS SECURED AGAINST YIELDING SIDEWAYS.

Span in Feet.	B 30						
	30 ²¹ / ₃₂ "	30 ⁷ / ₁₆ "	30 ¹ / ₄ "	30 ³ / ₈ "	30"	29 ⁷ / ₈ "	29 ²⁵ / ₃₂ "
	163 Lbs.	149 Lbs.	137 Lbs.	129 Lbs.	121 Lbs.	115 Lbs.	110 Lbs.
	362.9						
14	361.5	311.9					
15	337.4	308.7	270.4				
16	316.3	289.4	265.6	238.3			
17	297.7	272.4	250.0	234.2	214.6	199.0	191.1
18	281.2	257.2	236.1	221.2	208.2	196.1	186.6
19	266.4	243.7	223.7	209.6	197.2	185.7	176.7
20	253.1	231.5	212.5	199.1	187.4	176.5	167.9
21	241.0	220.5	202.4	189.6	178.4	168.0	159.9
22	230.0	210.5	193.2	181.0	170.3	160.4	152.6
23	220.0	201.3	184.8	173.1	162.9	153.4	146.0
24	210.9	192.9	177.1	165.9	156.1	147.0	139.9
25	202.4	185.2	170.0	159.3	149.9	141.2	134.3
26	194.7	178.1	163.5	153.2	144.1	135.7	129.2
27	187.4	171.5	157.4	147.5	138.8	130.7	124.4
28	180.8	165.4	151.8	142.2	133.8	126.0	119.9
29	174.5	159.7	146.6	137.3	129.2	121.7	115.8
30	168.7	154.3	141.7	132.7	124.9	117.6	111.9
31	163.3	149.4	137.1	128.5	120.9	113.8	108.3
32	158.2	144.7	132.8	124.4	117.1	110.3	104.9
33	153.4	140.3	128.8	120.7	113.5	106.9	101.8
34	148.9	136.2	125.0	117.1	110.2	103.8	98.8
35	144.6	132.3	121.4	113.8	107.1	100.8	95.9
36	140.6	128.6	118.1	110.6	104.1	98.0	93.3
37	136.8	125.1	114.9	107.6	101.3	95.4	90.8
38	133.2	121.8	111.8	104.8	98.6	92.9	88.4
39	129.8	118.7	109.0	102.1	96.1	90.5	86.1
40	126.5	115.8	106.3	99.6	93.7	88.2	84.0
41	123.4	112.9	103.7	97.1	91.4	86.1	81.9
42	120.5	110.2	101.2	94.8	89.2	84.0	80.0
43	117.7	107.7	98.8	92.6	87.1	82.1	78.1
44	115.0	105.2	96.6	90.5	85.2	80.2	76.3
45	112.5	102.9	94.4	88.5	83.3	78.4	74.6
46	110.0	100.7	92.4	86.6	81.5	76.7	73.0
47	107.7	98.5	90.4	84.7	79.7	75.1	71.4
48	105.4	96.5	88.5	83.0	78.1	73.5	70.0
49	103.3	94.5	86.7	81.3	76.5	72.0	68.5

Safe loads given include weight of beam.

Greatest safe loads limited by web shear or buckling are given above the heavy line.

SAFE LOADS UNIFORMLY DISTRIBUTED FOR

**BETHLEHEM I BEAMS,
IN THOUSANDS OF POUNDS.**MAXIMUM FIBER STRESS, 16,000 POUNDS PER SQUARE INCH.
BEAMS SECURED AGAINST YIELDING SIDEWAYS.

Span in Feet.	B 28						
	28 ¹ / ₂ "	28 ³ / ₄ "	28 ¹ / ₄ "	28 ⁵ / ₈ "	28"	27 ⁷ / ₈ "	27 ¹ / ₁₆ "
	133 Lbs.	119 Lbs.	112 Lbs.	104 Lbs.	97 Lbs.	91 Lbs.	85 Lbs.
	275.7						
15	258.9	225.5					
16	242.7	218.3	202.9				141.5
17	228.4	205.5	192.2	177.4			139.4
18	215.7	194.1	181.6	168.7	156.3	142.5	131.6
19	204.4	183.8	172.0	159.8	148.8	138.6	124.7
20	194.2	174.7	163.4	151.9	141.4	131.7	118.5
21	184.9	166.3	156.6	146.6	134.7	125.4	112.8
22	176.5	158.8	148.5	138.0	128.5	119.7	107.7
23	168.8	151.9	142.1	132.0	123.0	114.5	103.0
24	161.8	145.5	136.2	126.5	117.8	109.7	98.7
25	155.3	139.7	130.7	121.5	113.1	105.3	94.8
26	149.3	134.3	125.7	116.8	108.8	101.3	91.1
27	143.8	129.4	121.0	112.5	104.7	97.5	87.7
28	138.7	124.8	116.7	108.5	101.0	94.0	84.6
29	133.9	120.4	112.7	104.7	97.5	90.8	81.7
30	129.4	116.4	108.9	101.2	94.3	87.8	79.0
31	125.3	112.7	105.4	98.0	91.2	84.9	76.4
32	121.3	109.2	102.1	94.9	88.4	82.3	74.0
33	117.7	105.8	99.0	92.0	85.7	79.8	71.8
34	114.2	102.7	96.1	89.3	83.2	77.4	69.7
35	110.9	99.8	93.4	86.8	80.8	75.2	67.7
36	107.9	97.0	90.8	84.4	78.6	73.1	65.8
37	104.9	94.4	88.3	82.1	76.4	71.2	64.0
38	102.2	91.9	86.0	79.9	74.4	69.3	62.3
39	99.6	89.6	83.8	77.9	72.5	67.5	60.7
40	97.1	87.3	81.7	75.9	70.7	65.8	59.2
41	94.7	85.2	79.7	74.1	69.0	64.2	57.8
42	92.5	83.2	77.8	72.3	67.3	62.7	56.4
43	90.3	81.2	76.0	70.6	65.8	61.2	55.1
44	88.3	79.4	74.3	69.0	64.3	59.8	53.8
45	86.3	77.6	72.6	67.5	62.8	58.5	52.6
46	84.4	75.9	71.0	66.0	61.5	57.2	51.5
47	82.6	74.3	69.5	64.6	60.2	56.0	50.4
48	80.9	72.8	68.1	63.3	58.9	54.9	49.4
49	79.2	71.3	66.7	62.0	57.7	53.7	48.3
50	77.7	69.9	65.4	60.7	56.6	52.7	47.4

Safe loads given include weight of beam.

Greatest safe loads limited by web shear or buckling are given above the heavy line.

SAFE LOADS UNIFORMLY DISTRIBUTED FOR

**BETHLEHEM I BEAMS,
IN THOUSANDS OF POUNDS.**MAXIMUM FIBER STRESS, 16,000 POUNDS PER SQUARE INCH.
BEAMS SECURED AGAINST YIELDING SIDEWAYS.

Span in Feet.	B 22				
	22¼"	22½"	22"	21⅞"	21¾"
	73 Lbs.	67.5 Lbs.	62.5 Lbs.	58 Lbs.	54.5 Lbs.
					90.7
14	122.6	108.2	96.9	91.2	86.4
15	114.9	105.3	96.7	88.7	80.6
16	107.7	98.7	90.6	83.1	75.6
17	101.4	92.9	85.3	78.2	71.1
18	95.7	87.7	80.6	73.9	67.2
19	90.7	83.1	76.3	70.0	63.6
20	86.1	79.0	72.5	66.5	60.5
21	82.0	75.2	69.0	63.3	57.6
22	78.3	71.8	65.9	60.5	55.0
23	74.9	68.7	63.0	57.8	52.6
24	71.8	65.8	60.4	55.4	50.4
25	68.9	63.2	58.0	53.2	48.4
26	66.3	60.7	55.8	51.2	46.5
27	63.8	58.5	53.7	49.3	44.8
28	61.5	56.4	51.8	47.5	43.2
29	59.4	54.4	50.0	45.9	41.7
30	57.4	52.6	48.3	44.3	40.3
31	55.6	50.9	46.8	42.9	39.0
32	53.8	49.3	45.3	41.6	37.8
33	52.2	47.8	43.9	40.3	36.6
34	50.7	46.4	42.6	39.1	35.6
35	49.2	45.1	41.4	38.0	34.5
36	47.9	43.9	40.3	36.9	33.6
37	46.6	42.7	39.2	35.9	32.7
38	45.3	41.6	38.2	35.0	31.8
39	44.2	40.5	37.2	34.1	31.0
40	43.1	39.5	36.3	33.3	30.2
41	42.0	38.5	35.4	32.4	29.5
42	41.0	37.6	34.5	31.7	28.8
43	40.1	36.7	33.7	30.9	28.1
44	39.2	35.9	33.0	30.2	27.5
45	38.3	35.1	32.2	29.6	26.9

Safe loads given include weight of beam.

Greatest safe loads limited by web shear or buckling are given above the heavy line.

Safe loads below the dotted line produce deflections exceeding 1/360 of the span.



SAFE LOADS, IN THOUSANDS OF POUNDS, FOR

BETHLEHEM GIRDER BEAMS USED AS COLUMNS.

Allowable Stress in Pounds per Square Inch:

15,000 for lengths under 60 radii.

$$1 + \frac{18,000}{l^2} \text{ for lengths over 60 radii.}$$

$$1 + \frac{18,000}{r^2}$$

Section Number.	Nominal Depth of Beam, Inches.	Weight per Foot, Pounds.	Area, Square Inches.	Least Radius of Gyration, Inches.	UNSUPPORTED LENGTH OF COLUMN, IN FEET.					
					13	14	15	16	17	18
G36	36 ²³ / ₃₂	300.0	88.12	3.66	1322	1322	1322	1322	1322	1322
	36 ¹ / ₂	280.0	82.45	3.62	1237	1237	1237	1237	1237	1237
	36 ¹ / ₄	260.0	76.50	3.57	1148	1148	1148	1148	1148	1144
	36 ¹ / ₈	250.0	73.61	3.54	1104	1104	1104	1104	1104	1098
	36	240.0	70.55	3.52	1058	1058	1058	1058	1058	1050
	35 ⁷ / ₈	230.0	67.67	3.49	1015	1015	1015	1015	1015	1004
G33	33 ⁵ / ₈	260.0	76.54	3.50	1148	1148	1148	1148	1148	1137
	33 ⁷ / ₁₆	245.0	72.19	3.47	1083	1083	1083	1083	1083	1069
	33 ¹ / ₄	230.0	67.85	3.43	1018	1018	1018	1018	1018	1001
	33 ¹ / ₈	220.0	64.80	3.41	972	972	972	972	972	954
	33	210.0	61.91	3.38	929	929	929	929	927	908
	32 ⁷ / ₈	200.0	58.87	3.36	883	883	883	883	880	862
G30	30 ³ / ₄	240.0	70.60	3.36	1059	1059	1059	1059	1055	1034
	30 ¹ / ₂	220.0	64.82	3.32	972	972	972	972	964	945
	30 ¹ / ₄	200.0	58.92	3.28	884	884	884	884	873	855
	30 ¹ / ₈	190.0	55.90	3.26	839	839	839	839	826	809
	30	180.0	53.20	3.23	798	798	798	798	784	767
	29 ⁷ / ₈	173.0	50.80	3.20	762	762	762	762	746	730
G28	28 ⁵ / ₁₆	186.0	54.73	3.14	821	821	821	816	798	780
	28 ¹ / ₈	175.0	51.45	3.09	772	772	772	763	746	728
	28	165.0	48.75	3.07	731	731	731	721	705	688
	27 ⁷ / ₈	156.0	45.93	3.04	689	689	689	677	661	646
	27 ³ / ₄	145.0	42.69	3.02	640	640	640	627	613	598
G22	22 ³ / ₈	132.0	38.96	2.95	584	584	581	568	554	540
	22 ¹ / ₄	124.0	36.59	2.92	549	549	544	531	518	505
	22 ¹ / ₈	116.0	34.12	2.90	512	512	506	494	482	469
	22	108.0	31.89	2.87	478	478	471	460	448	437
	21 ⁷ / ₈	101.0	29.68	2.83	445	445	436	425	415	404

Beams not secured against yielding sideways and free to fail in the direction of the least Radius of Gyration.

SAFE LOADS, IN THOUSANDS OF POUNDS, FOR

BETHLEHEM GIRDER BEAMS USED AS COLUMNS.

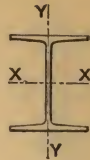

Allowable Stress in Pounds per Square Inch:

15,000 for lengths under 60 radii.

$$1 + \frac{18,000}{18,000 r^2} \text{ for lengths over 60 radii.}$$

UNSUPPORTED LENGTH OF COLUMN, IN FEET.										BENDING FACTORS.		Section Number.
20	22	24	26	28	30	32	34	36	38	AXIS X-X. k	AXIS Y-Y. k'	
1280	1230	1180	1130	1080	1032	984	938	894	852	.080	.623	G36
1193	1146	1098	1051	1004	958	913	870	829	789	.080	.633	
1101	1056	1011	967	923	880	838	798	759	722	.081	.650	
1055	1012	969	926	883	842	801	762	725	689	.081	.659	
1009	968	926	884	843	803	764	727	691	657	.081	.666	
965	924	884	844	804	766	728	692	658	625	.081	.676	
1092	1047	1001	956	911	868	826	785	746	709	.087	.647	G33
1027	983	940	897	854	813	773	735	698	663	.087	.658	
960	919	878	837	797	758	720	684	649	616	.087	.671	
915	875	835	796	758	720	684	650	617	585	.087	.680	
871	832	794	756	719	684	649	616	584	554	.088	.688	
826	789	753	716	681	647	614	583	552	524	.088	.696	
990	946	902	859	817	776	736	699	662	628	.095	.671	G30
904	863	823	783	744	706	669	634	601	570	.095	.685	
817	780	743	706	670	635	602	570	540	511	.095	.700	
773	738	702	667	633	600	568	538	509	482	.095	.709	
733	698	664	631	598	567	536	508	480	454	.096	.719	
697	664	631	598	567	537	508	480	454	430	.096	.733	
744	707	671	636	602	569	538	508	480	454	.102	.725	G28
694	659	625	591	559	528	498	470	444	419	.103	.748	
655	622	589	558	527	497	469	443	418	394	.103	.758	
614	583	552	522	492	465	438	413	390	367	.103	.767	
569	539	511	482	455	429	405	382	360103	.775	
513	485	459	433	408	384	361	340	320125	.752	
479	453	428	403	379	357	336	316	297125	.765	G22
445	421	397	373	352	331	311	293	275125	.777	
413	390	368	347	326	306	288	270125	.792	
382	360	339	319	300	281	264	248125	.808	

Loads to the right of the heavy line are for lengths greater than 120 radii.

SAFE LOADS, IN THOUSANDS OF POUNDS, FOR

BETHLEHEM I BEAMS USED AS COLUMNS.

Allowable Stress in Pounds per Square Inch:

15,000 for lengths under 60 radii.

18,000

for lengths over 60 radii.

$$1 + \frac{l^2}{18,000 r^2}$$

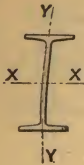

Section Number.	Nominal Depth of Beam, Inches.	Weight per Foot, Pounds.	Area, Square Inches.	Least Radius of Gyration, Inches.	UNSUPPORTED LENGTH OF COLUMN, IN FEET.					
					7	8	9	10	11	12
B36	36 ¹⁷ / ₃₂	190.0	55.87	2.48	838	838	838	838	838	838
	36 ¹ / ₄	173.0	50.94	2.43	764	764	764	764	764	764
	36 ¹ / ₈	164.0	48.10	2.41	722	722	722	722	722	722
	36	155.0	45.58	2.39	684	684	684	684	684	684
	35 ²⁹ / ₃₂	147.0	43.23	2.37	648	648	648	648	648	648
B33	33 ¹ / ₂	165.0	48.52	2.34	728	728	728	728	728	722
	33 ⁹ / ₃₂	152.0	44.65	2.29	670	670	670	670	670	659
	33 ¹ / ₈	143.0	42.05	2.26	631	631	631	631	631	618
	33	135.0	39.55	2.24	593	593	593	593	593	579
	32 ⁷ / ₈	125.0	36.83	2.23	552	552	552	552	552	538
B30	30 ²¹ / ₃₂	163.0	48.00	2.24	720	720	720	720	720	703
	30 ⁷ / ₁₆	149.0	43.93	2.21	659	659	659	659	659	640
	30 ¹ / ₄	137.0	40.40	2.18	606	606	606	606	604	585
	30 ¹ / ₈	129.0	37.82	2.17	567	567	567	567	565	547
	30	121.0	35.65	2.15	535	535	535	535	531	514
	29 ⁷ / ₈	115.0	33.80	2.12	507	507	507	507	501	484
	29 ²⁵ / ₃₂	110.0	32.45	2.09	487	487	487	487	478	462
B28	28 ¹⁹ / ₃₂	133.0	39.09	2.12	586	586	586	586	579	560
	28 ³ / ₈	119.0	35.11	2.09	527	527	527	527	517	500
	28 ¹ / ₄	112.0	32.95	2.07	494	494	494	494	484	467
	28 ¹ / ₈	104.0	30.66	2.05	460	460	460	460	449	433
	28	97.0	28.61	2.03	429	429	429	429	417	402
	27 ⁷ / ₈	91.0	26.86	1.99	403	403	403	402	389	375
	27 ¹ / ₁₆	85.0	24.96	1.91	374	374	374	368	355	341
B22	22 ¹ / ₄	73.0	21.51	1.79	323	323	322	310	297	285
	22 ¹ / ₈	67.5	19.84	1.76	298	298	295	284	272	260
	22	62.5	18.38	1.73	276	276	272	261	250	239
	21 ⁷ / ₈	58.0	17.14	1.69	257	257	251	241	230	220
	21 ³ / ₄	54.5	16.04	1.62	241	241	232	221	211	201

Beams not secured against yielding sideways and free to fail in the direction of the least Radius of Gyration.

SAFE LOADS, IN THOUSANDS OF POUNDS, FOR

**BETHLEHEM I BEAMS
USED AS COLUMNS.**

Allowable Stress in Pounds per Square Inch:

15,000 for lengths under 60 radii.

$$1 + \frac{18,000}{l^2} \text{ for lengths over 60 radii.}$$

$$\frac{18,000}{r^2}$$

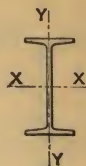

UNSUPPORTED LENGTH OF COLUMN, IN FEET.										BENDING FACTORS.		Section Number.
13	14	15	16	17	18	20	22	24	26	AXIS X-X. k	AXIS Y-Y. k'	
824	801	778	754	731	707	661	617	575	535	.085	.981	B36
746	725	703	681	659	637	595	554	515	479	.086	1.020	
702	682	661	640	619	599	558	519	483	448	.086	1.035	
663	644	624	604	584	564	526	489	454	421	.086	1.052	
627	608	589	570	551	532	496	461	427	396	.086	1.063	
700	679	657	636	614	593	551	512	474	439	.092	1.037	B33
639	619	598	578	558	538	499	462	428	396	.093	1.075	
598	579	560	540	521	502	465	431	398	368	.094	1.103	
561	542	524	506	487	469	435	402	371	343	.094	1.120	
521	504	487	470	453	436	403	373	344	318	.093	1.126	
681	658	636	614	591	570	528	488	450	416	.101	1.069	B30
619	599	578	557	537	517	478	441	407	375	.101	1.087	
566	547	527	508	489	471	435	401	369	340	.101	1.109	
529	511	492	474	457	439	405	374	344	317	.101	1.121	
496	479	462	445	428	411	379	349	321	296	.101	1.139	
468	451	434	418	402	386	355	327	300	276	.102	1.166	
446	430	414	398	382	367	337	310	284	261	.103	1.198	
541	522	502	483	465	446	411	378	347	319	.107	1.132	B28
483	465	448	430	413	397	365	335	308	282	.107	1.153	
451	434	418	401	385	370	340	312	286108	1.174	
418	402	386	371	356	341	313	287	263108	1.195	
388	373	358	344	330	316	290	266	243108	1.218	
360	346	332	319	305	292	267	244	223109	1.256	
328	314	301	288	275	263	239	218112	1.369	
272	260	248	236	225	214	194	175133	1.329	
249	237	226	215	204	194	176	159134	1.368	
228	217	207	196	187	177	160135	1.416	
209	199	189	180	171	162	146138	1.490	
191	181	171	162	154	145	130142	1.612	

Loads to the right of the heavy line are for lengths greater than 120 radii.

SAFE LOADS, IN THOUSANDS OF POUNDS, FOR

BETHLEHEM 10'' H COLUMNS.

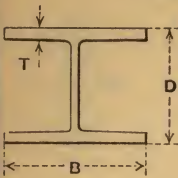

$$H \frac{10}{12}$$

Allowable Stress in Pounds per Square Inch:

15,000 for lengths under 60 radii.

$$\frac{18,000}{l^2}$$
 for lengths over 60 radii.

$$1 + \frac{18,000}{r^2}$$

Section Number.	Weight per Foot, Pounds.	DIMENSIONS, INCHES.			Area, Square Inches.	Least Radius of Gyration, Inches.	UNSUPPORTED LENGTH OF COLUMN, IN FEET.			
		D	T	B			14	15	16	17
	62.0	10	.615	11.99	18.29	3.04	274	274	269	263
	68.0	10 $\frac{1}{8}$.675	12.03	20.13	3.05	302	302	297	290
	75.0	10 $\frac{1}{4}$.740	12.06	22.00	3.08	330	330	326	318
	82.0	10 $\frac{3}{8}$.805	12.10	23.98	3.09	360	360	355	347
	88.0	10 $\frac{1}{2}$.865	12.14	25.86	3.11	388	388	384	376
	94.0	10 $\frac{5}{8}$.925	12.17	27.63	3.12	414	414	411	402
	100.0	10 $\frac{3}{4}$.990	12.20	29.54	3.14	443	443	440	431
	107.0	10 $\frac{7}{8}$	1.055	12.23	31.45	3.16	472	472	470	460
	113.0	11	1.115	12.26	33.25	3.17	499	499	497	487
	125.0	11	1.106	14.00	36.89	3.65	553	553	553	553
	133.0	11 $\frac{1}{8}$	1.166	14.04	39.02	3.66	585	585	585	585
	140.0	11 $\frac{1}{4}$	1.231	14.08	41.29	3.68	619	619	619	619
	148.0	11 $\frac{3}{8}$	1.296	14.11	43.46	3.69	652	652	652	652
	155.0	11 $\frac{1}{2}$	1.356	14.15	45.62	3.70	684	684	684	684
	162.0	11 $\frac{5}{8}$	1.416	14.19	47.78	3.72	717	717	717	717
	170.0	11 $\frac{3}{4}$	1.481	14.22	49.98	3.73	750	750	750	750
	177.0	11 $\frac{7}{8}$	1.546	14.25	52.18	3.74	783	783	783	783
	185.0	12	1.606	14.29	54.37	3.76	816	816	816	816
	192.0	12 $\frac{1}{8}$	1.666	14.32	56.45	3.77	847	847	847	847
	200.0	12 $\frac{1}{4}$	1.731	14.36	58.80	3.78	882	882	882	882
	208.0	12 $\frac{3}{8}$	1.796	14.40	61.17	3.79	918	918	918	918
	215.0	12 $\frac{1}{2}$	1.856	14.43	63.27	3.80	949	949	949	949
	222.0	12 $\frac{5}{8}$	1.916	14.46	65.38	3.81	981	981	981	981
	230.0	12 $\frac{3}{4}$	1.981	14.50	67.77	3.83	1017	1017	1017	1017
	238.0	12 $\frac{7}{8}$	2.046	14.53	70.04	3.84	1051	1051	1051	1051
	246.0	13	2.106	14.57	72.30	3.85	1085	1085	1085	1085

H $\frac{10}{12}$

SAFE LOADS, IN THOUSANDS OF POUNDS, FOR

BETHLEHEM 10'' H COLUMNS.

$$H_{12}^{10}$$

Allowable Stress in Pounds per Square Inch:

15,000 for lengths under 60 radii.

$$\frac{18,000}{1 + \frac{l^2}{18,000 r^2}} \text{ for lengths over 60 radii.}$$

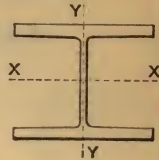

UNSUPPORTED LENGTH OF COLUMN, IN FEET.									BENDING FACTORS.		Weight per Foot, Pounds.
18	19	20	24	28	32	36	40	44	AXIS X-X. k	AXIS Y-Y. k'	
257	251	245	220	196	175	155	138	123	.261	.650	62.0
283	277	270	242	216	193	171	153	136	.261	.645	68.0
311	304	296	267	238	212	189	169	150	.260	.637	75.0
339	331	323	291	261	232	207	184	165	.260	.632	82.0
367	358	350	315	282	252	225	200	179	.260	.628	88.0
393	384	374	338	302	270	241	215	192	.259	.623	94.0
421	411	401	362	325	290	259	231	207	.259	.618	100.0
449	439	429	387	348	311	278	248	222	.258	.613	107.0
476	465	454	410	369	330	295	263	236	.257	.610	113.0
553	546	535	493	451	411	373	339	307	.253	.525	125.0
585	578	567	523	478	436	396	359	326	.253	.523	133.0
619	613	601	555	508	463	421	382	347	.253	.521	140.0
652	645	633	584	536	488	444	403	366	.252	.517	148.0
684	678	666	614	563	514	467	424	385	.252	.516	155.0
717	712	699	645	592	540	492	447	406	.251	.514	162.0
750	745	731	676	620	566	515	469	426	.251	.511	170.0
783	779	764	706	648	592	539	490	446	.250	.508	177.0
816	813	798	738	678	620	565	514	467	.250	.507	185.0
847	845	829	767	705	645	588	535	486	.249	.505	192.0
882	880	865	800	736	673	613	558	508	.249	.503	200.0
918	917	900	834	766	701	639	582	530	.248	.501	208.0
949	949	932	863	794	727	663	604	549	.248	.499	215.0
981	981	964	893	822	752	687	625	569	.247	.497	222.0
1017	1017	1001	928	855	783	715	651	593	.246	.495	230.0
1051	1051	1036	961	885	810	740	675	615	.246	.493	238.0
1085	1085	1070	993	914	838	766	698	636	.245	.492	246.0

Loads to the right of the heavy line are for lengths greater than 120 radii.

SAFE LOADS, IN THOUSANDS OF POUNDS, FOR

BETHLEHEM STANCHIONS.

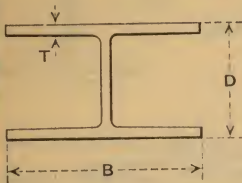

$$H \frac{6}{10}$$

Allowable Stress in Pounds per Square Inch:

15,000 for lengths under 60 radii.

18,000 for lengths over 60 radii.

$$1 + \frac{l^2}{18,000 r^2}$$

Section Number.	Weight per Foot, Pounds.	DIMENSIONS, INCHES.			Area, Square Inches.	Least Radius of Gyration, Inches.	UNSUPPORTED LENGTH OF COLUMN, IN FEET.				
		D	T	B			11	12	13	14	15
H $\frac{6}{10}$	40.0	6.216	.465	9.875	11.71	2.46	176	176	172	167	162
	46.0	6.356	.535	9.944	13.54	2.49	203	203	200	195	189
	53.0	6.512	.613	10.022	15.59	2.52	234	234	231	225	219
	60.0	6.666	.690	10.099	17.65	2.55	265	265	263	256	249
	67.0	6.818	.766	10.175	19.70	2.58	296	296	295	287	279
	73.0	6.946	.830	10.241	21.47	2.60	322	322	322	314	305
	80.0	7.096	.905	10.315	23.53	2.62	353	353	353	345	336
	88.0	7.265	.989	10.400	25.89	2.65	388	388	388	381	371

SAFE LOADS, IN THOUSANDS OF POUNDS, FOR

BETHLEHEM STANCHIONS.

$$H \frac{6}{10}$$

Allowable Stress in Pounds per Square Inch:

15,000 for lengths under 60 radii.

18,000 for lengths over 60 radii.

$$1 + \frac{18,000}{r^2}$$

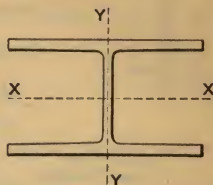

UNSUPPORTED LENGTH OF COLUMN, IN FEET.									BENDING FACTORS.		Weight per Foot, Pounds.
16	17	18	19	20	22	24	26	28	AXIS X-X. k	AXIS Y-Y. k'	
157	153	148	143	138	129	120	111	104	.443	.814	40.0
183	178	172	166	161	150	140	130	121	.442	.800	46.0
212	206	199	193	187	174	163	152	141	.441	.787	53.0
242	234	227	220	213	199	186	173	162	.439	.776	60.0
271	263	255	247	239	224	210	196	183	.438	.766	67.0
297	288	279	271	262	246	230	215	200	.437	.758	73.0
326	317	307	298	289	271	253	237	221	.435	.749	80.0
361	351	340	330	320	300	281	263	246	.433	.740	88.0

Loads to the right of the heavy line are for lengths greater than 120 radii.

SAFE LOADS, IN THOUSANDS OF POUNDS, FOR

BETHLEHEM GIRDER BEAMS USED AS COLUMNS.

COMPUTED ACCORDING TO THE BUILDING LAWS OF
NEW YORK AND CHICAGO.

Allowable Stress in Pounds per Square Inch:

$$16,000 - 70 \frac{l}{r}$$

14,000 maximum stress for Chicago.



Section Number.	Nominal Depth of Beam, Inches.	Weight per Foot, Pounds.	Area, Square Inches.	Least Radius of Gyration, Inches.	Maximum Safe Load for Chicago.	UNSUPPORTED LENGTH OF COLUMN, IN FEET.				
						8	9	10	11	12
G36	36 ²³ / ₃₂	300.0	88.12	3.66	1234	1248	1228	1208	1187	1167
	36 ¹ / ₂	280.0	82.45	3.62	1154	1166	1147	1128	1109	1090
	36 ¹ / ₄	260.0	76.50	3.57	1071	1080	1062	1044	1026	1008
	36 ¹ / ₈	250.0	73.61	3.54	1031	1038	1021	1003	986	968
	36	240.0	70.55	3.52	988	994	977	960	944	927
	35 ⁷ / ₈	230.0	67.67	3.49	947	952	936	920	904	887
G33	33 ⁵ / ₈	260.0	76.54	3.50	1072	1078	1059	1041	1023	1004
	33 ⁷ / ₁₆	245.0	72.19	3.47	1011	1015	998	980	963	945
	33 ¹ / ₄	230.0	67.85	3.43	950	953	936	919	903	886
	33 ¹ / ₈	220.0	64.80	3.41	907	909	893	877	861	845
	33	210.0	61.91	3.38	867	866	852	837	821	806
	32 ⁷ / ₈	200.0	58.87	3.36	824	824	809	795	780	765
G30	30 ³ / ₄	240.0	70.60	3.36	988	988	971	953	935	918
	30 ¹ / ₂	220.0	64.82	3.32	907	906	890	873	857	840
	30 ¹ / ₄	200.0	58.92	3.28	825	822	807	792	777	762
	30 ¹ / ₈	190.0	55.90	3.26	783	779	765	750	736	722
	30	180.0	53.20	3.23	745	741	727	713	699	685
	29 ⁷ / ₈	173.0	50.80	3.20	711	706	693	679	666	653
G28	28 ⁵ / ₁₆	186.0	54.73	3.14	766	759	744	729	715	700
	28 ¹ / ₈	175.0	51.45	3.09	720	711	697	683	669	655
	28	165.0	48.75	3.07	683	673	660	647	633	620
	27 ⁷ / ₈	156.0	45.93	3.04	643	633	621	608	595	583
	27 ³ / ₄	145.0	42.69	3.02	598	588	576	564	552	541
G22	22 ³ / ₈	132.0	38.96	2.95	545	535	524	512	501	490
	22 ¹ / ₄	124.0	36.59	2.92	512	501	491	480	470	459
	22 ¹ / ₈	116.0	34.12	2.90	478	467	457	447	437	427
	22	108.0	31.89	2.87	446	436	426	417	408	398
	21 ⁷ / ₈	101.0	29.68	2.83	416	404	396	387	378	369

Beams not secured against yielding sideways and free to fail in the direction of the least Radius of Gyration.

SAFE LOADS, IN THOUSANDS OF POUNDS, FOR

**BETHLEHEM GIRDER BEAMS
USED AS COLUMNS.**

COMPUTED ACCORDING TO THE BUILDING LAWS OF
NEW YORK AND CHICAGO.

Allowable Stress in Pounds per Square Inch:

$$16,000 - 70 \frac{l}{r}$$

14,000 maximum stress for Chicago.

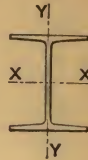

UNSUPPORTED LENGTH OF COLUMN, IN FEET.										BENDING FACTORS.		Section Number.
14	16	18	20	22	24	26	28	32	36	AXIS X-X. k	AXIS Y-Y. k'	
1127	1086	1046	1005	965	925	884	844	763	682	.080	.623	G36
1051	1013	975	937	898	860	822	784	707	630	.080	.633	
972	936	900	864	828	792	756	720	648	576	.081	.650	
933	898	863	828	793	759	724	689	619	549	.081	.659	
893	859	826	792	758	725	691	657	590	523	.081	.666	
855	822	790	757	724	692	659	627	562	496	.081	.676	
967	931	894	857	821	784	747	710	637	563	.087	.647	G33
910	875	840	806	771	736	701	666	596	526	.087	.658	
853	820	787	753	720	687	654	620	554	487	.087	.671	
813	781	749	718	686	654	622	590	526	462	.087	.680	
775	744	714	683	652	621	591	560	498	437	.088	.688	
736	706	677	648	618	589	559	530	471	412	.088	.696	
883	847	812	777	741	706	671	635	565	494	.095	.671	G30
808	775	742	709	676	644	611	578	512	447	.095	.685	
731	701	671	641	611	581	550	520	460	400	.095	.700	
693	664	635	606	578	549	520	491	433	376	.095	.709	
658	630	602	574	547	519	491	464	408	353	.096	.719	
626	599	573	546	519	493	466	439	386	333	.096	.733	
671	641	612	583	554	524	495	466	407	349	.102	.725	G28
627	599	571	543	515	488	460	432	376	320	.103	.748	
593	567	540	513	487	460	433	407	353	300	.103	.758	
557	532	506	481	456	430	405	380	329	278	.103	.767	
517	493	469	446	422	398	374	351	303	256	.103	.775	
468	446	424	401	379	357	335	313	268	224	.125	.752	
438	417	396	375	354	333	312	291	249	207	.125	.765	
408	388	368	348	328	309	289	269	230	190	.125	.777	
380	361	342	324	305	286	268	249	212	174	.125	.792	
352	334	316	299	281	263	246	228	193	158	.125	.808	

Loads to the right of the heavy line are for lengths greater than 120 radii but not exceeding 150 radii.

SAFE LOADS, IN THOUSANDS OF POUNDS, FOR

BETHLEHEM I BEAMS USED AS COLUMNS.

COMPUTED ACCORDING TO THE BUILDING LAWS OF
NEW YORK AND CHICAGO.

Allowable Stress in Pounds per Square Inch:

$$16,000 - 70 \frac{l}{r}.$$

14,000 maximum stress for Chicago.

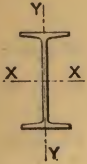

Section Number.	Nominal Depth of Beam, Inches.	Weight per Foot, Pounds.	Area, Square Inches.	Least Radius of Gyration, Inches.	Maximum Safe Load for Chicago.	UNSUPPORTED LENGTH OF COLUMN, IN FEET.				
						5	6	7	8	9
B36	36 $\frac{17}{32}$	190.0	55.87	2.48	782	797	779	761	743	724
	36 $\frac{1}{4}$	173.0	50.94	2.43	713	727	709	692	674	657
	36 $\frac{1}{8}$	164.0	48.10	2.41	673	686	669	652	635	619
	36	155.0	45.58	2.39	638	649	633	617	601	585
	35 $\frac{29}{32}$	147.0	43.23	2.37	605	615	600	584	569	554
B33	33 $\frac{1}{2}$	165.0	48.52	2.34	679	689	672	654	637	620
	33 $\frac{9}{32}$	152.0	44.65	2.29	625	633	616	600	583	567
	33 $\frac{1}{8}$	143.0	42.05	2.26	589	595	579	563	548	532
	33	135.0	39.55	2.24	554	559	544	529	514	499
	32 $\frac{7}{8}$	125.0	36.83	2.23	516	520	506	492	478	464
B30	30 $\frac{21}{32}$	163.0	48.00	2.24	672	678	660	642	624	606
	30 $\frac{7}{16}$	149.0	43.93	2.21	615	619	603	586	569	553
	30 $\frac{1}{4}$	137.0	40.40	2.18	566	569	553	537	522	506
	30 $\frac{1}{8}$	129.0	37.82	2.17	529	532	517	503	488	473
	30	121.0	35.65	2.15	499	501	487	473	459	445
	29 $\frac{7}{8}$	115.0	33.80	2.12	473	474	460	447	434	420
	29 $\frac{25}{32}$	110.0	32.45	2.09	454	454	441	428	415	402
B28	28 $\frac{19}{32}$	133.0	39.09	2.12	547	548	533	517	502	486
	28 $\frac{3}{8}$	119.0	35.11	2.09	492	491	477	463	449	435
	28 $\frac{1}{4}$	112.0	32.95	2.07	461	460	447	434	420	407
	28 $\frac{1}{8}$	104.0	30.66	2.05	429	428	415	403	390	377
	28	97.0	28.61	2.03	401	399	387	375	363	351
	27 $\frac{7}{8}$	91.0	26.86	1.99	376	373	362	350	339	328
	27 $\frac{11}{16}$	85.0	24.96	1.91	349	344	334	323	312	301
B22	22 $\frac{1}{4}$	73.0	21.51	1.79	301	294	284	274	263	253
	22 $\frac{1}{8}$	67.5	19.84	1.76	278	270	261	251	242	232
	22	62.5	18.38	1.73	257	249	241	232	223	214
	21 $\frac{7}{8}$	58.0	17.14	1.69	240	232	223	215	206	198
	21 $\frac{3}{4}$	54.5	16.04	1.62	225	215	207	198	190	182

Beams not secured against yielding sideways and free to fail in the direction of the least Radius of Gyration.

SAFE LOADS, IN THOUSANDS OF POUNDS, FOR

**BETHLEHEM I BEAMS
USED AS COLUMNS.**

COMPUTED ACCORDING TO THE BUILDING LAWS OF
NEW YORK AND CHICAGO.

Allowable Stress in Pounds per Square Inch:

$$16,000 - 70 \frac{l}{r}$$

14,000 maximum stress for Chicago.

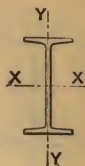

UNSUPPORTED LENGTH OF COLUMN, IN FEET.										BENDING FACTORS.		Section Number.
10	11	12	13	14	16	18	20	22	24	AXIS X-X. k	AXIS Y-Y. k'	
705	686	667	648	629	591	553	515	478	440	.085	.981	B36
639	621	604	586	569	533	498	463	428	392	.086	1.020	
602	585	568	552	535	501	468	434	401	367	.086	1.035	
569	553	537	521	505	473	441	409	377	345	.086	1.052	
538	523	508	492	477	447	416	385	355	324	.086	1.063	
602	585	567	550	532	498	463	428	393	358	.092	1.037	B33
551	534	518	501	485	452	420	387	354	321	.093	1.075	
517	501	485	470	454	423	391	360	329	298	.094	1.103	
484	470	455	440	425	396	366	336	307	277	.094	1.120	
451	437	423	409	395	367	340	312	284	256	.093	1.126	
588	570	552	534	516	480	444	408	372	336	.101	1.069	B30
536	519	503	486	469	436	402	369	336	302	.101	1.087	
491	475	460	444	428	397	366	335	304	273	.101	1.107	
459	444	429	415	400	371	342	312	283	254	.101	1.121	
431	417	403	389	375	348	320	292	264	236	.101	1.139	
407	393	380	367	353	327	300	273	246	219	.102	1.166	B28
389	376	363	350	337	311	284	258	232	206	.103	1.198	
471	455	440	424	409	378	347	318	285	254	.107	1.132	
421	407	392	378	364	336	308	280	251	223	.107	1.153	
393	380	367	353	340	313	287	260	233	206	.108	1.174	
365	352	340	327	315	290	264	239	214	189	.108	1.195	B22
339	328	316	304	292	268	245	221	197	174	.108	1.218	
316	305	294	282	271	248	226	203	180	158	.109	1.256	
290	279	268	257	246	224	202	180	158112	1.369	
243	233	223	213	203	183	162	142	122133	1.329	
223	213	204	194	185	166	147	128	109134	1.368	
205	196	187	178	169	151	133	116135	1.416	
189	181	172	163	155	138	121	104138	1.490	
173	165	157	149	140	124	107	90142	1.613	

Loads to the right of the heavy line are for lengths greater than 120 radii but not exceeding 150 radii.

SAFE LOADS, IN THOUSANDS OF POUNDS, FOR

BETHLEHEM 10'' H COLUMNS.

H₁₂¹⁰COMPUTED ACCORDING TO THE BUILDING LAWS OF
NEW YORK AND CHICAGO.

Allowable Stress in Pounds per Square Inch:

$$16,000 - 70 \frac{l}{r}$$

14,000 maximum stress for Chicago.

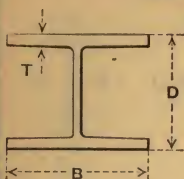

Section Number.	Weight per Foot, Pounds.	DIMENSIONS, INCHES.			Area, Square Inches.	Least Radius of Gyration, Inches.	Maximum Safe Load for Chicago.	UNSUPPORTED LENGTH, IN FEET.		
		D	T	B				8	9	10
	62.0	10	.615	11.99	18.29	3.04	256	252	247	242
	68.0	10 $\frac{1}{8}$.675	12.03	20.13	3.05	282	278	272	267
	75.0	10 $\frac{1}{4}$.740	12.06	22.00	3.08	308	304	298	292
	82.0	10 $\frac{3}{8}$.805	12.10	23.98	3.09	336	332	325	318
	88.0	10 $\frac{1}{2}$.865	12.14	25.86	3.11	362	358	351	344
	94.0	10 $\frac{5}{8}$.925	12.17	27.63	3.12	387	383	375	368
	100.0	10 $\frac{3}{4}$.990	12.20	29.54	3.14	414	409	402	394
	107.0	10 $\frac{7}{8}$	1.055	12.23	31.45	3.16	440	436	428	420
	113.0	11	1.115	12.26	33.25	3.17	466	462	453	444
	125.0	11	1.106	14.00	36.89	3.65	516	522	514	505
	133.0	11 $\frac{1}{8}$	1.166	14.04	39.02	3.66	546	553	544	535
	140.0	11 $\frac{1}{4}$	1.231	14.08	41.29	3.68	578	585	576	566
	148.0	11 $\frac{3}{8}$	1.296	14.11	43.46	3.69	608	616	606	596
	155.0	11 $\frac{1}{2}$	1.356	14.15	45.62	3.70	639	647	637	626
	162.0	11 $\frac{5}{8}$	1.416	14.19	47.78	3.72	669	678	667	657
	170.0	11 $\frac{3}{4}$	1.481	14.22	49.98	3.73	700	710	698	687
	177.0	11 $\frac{7}{8}$	1.546	14.25	52.18	3.74	731	741	729	718
	185.0	12	1.606	14.29	54.37	3.76	761	773	761	748
	192.0	12 $\frac{1}{8}$	1.666	14.32	56.45	3.77	790	803	790	777
	200.0	12 $\frac{1}{4}$	1.731	14.36	58.80	3.78	823	836	823	810
	208.0	12 $\frac{3}{8}$	1.796	14.40	61.17	3.79	856	870	857	843
	215.0	12 $\frac{1}{2}$	1.856	14.43	63.27	3.80	886	900	886	872
	222.0	12 $\frac{5}{8}$	1.916	14.46	65.38	3.81	915	931	916	902
	230.0	12 $\frac{3}{4}$	1.981	14.50	67.77	3.83	949	965	951	936
	238.0	12 $\frac{7}{8}$	2.046	14.53	70.04	3.84	981	998	983	967
	246.0	13	2.106	14.57	72.30	3.85	1012	1031	1015	999

H₁₂¹⁰

SAFE LOADS, IN THOUSANDS OF POUNDS, FOR
BETHLEHEM 10'' H COLUMNS.

$$H \frac{10}{12}$$

COMPUTED ACCORDING TO THE BUILDING LAWS OF
 NEW YORK AND CHICAGO.

Allowable Stress in Pounds per Square Inch:

$$16,000 - 70 \frac{l}{r}.$$

14,000 maximum stress for Chicago.

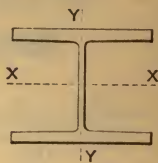

UNSUPPORTED LENGTH OF COLUMN, IN FEET.										BENDING FACTORS.		Weight per Foot, Pounds.
12	14	16	18	20	24	28	32	36	40	AXIS X-X, k	AXIS Y-Y, k'	
232	222	212	202	192	171	151	131	111	90	.261	.650	62.0
256	244	233	222	211	189	167	145	123	100	.261	.645	68.0
280	268	256	244	232	208	184	160	136	112	.260	.637	75.0
305	292	279	266	253	227	201	175	149	123	.260	.632	82.0
330	316	302	288	274	246	218	190	162	134	.260	.628	88.0
353	338	323	308	293	264	234	204	174	145	.259	.623	94.0
378	362	346	330	315	283	251	220	188	157	.259	.618	100.0
403	386	369	353	336	303	269	236	202	169	.258	.613	107.0
426	409	391	373	356	321	285	250	215	180	.257	.610	113.0
488	471	454	437	420	386	353	319	285	251	.253	.525	125.0
517	499	481	463	445	409	374	338	302	266	.253	.523	133.0
548	529	510	491	472	434	397	359	321	284	.253	.521	140.0
577	557	537	517	497	458	418	379	339	300	.252	.517	148.0
606	585	564	543	523	481	440	399	357	316	.252	.516	155.0
635	613	592	570	549	506	462	419	376	333	.251	.514	162.0
665	642	620	597	575	530	485	440	394	349	.251	.511	170.0
694	671	647	624	600	554	507	460	413	366	.250	.508	177.0
724	700	676	651	627	578	530	481	433	384	.250	.507	185.0
752	727	702	677	652	601	551	501	450	400	.249	.505	192.0
784	758	732	706	679	627	575	523	470	418	.249	.503	200.0
816	789	762	735	708	653	599	545	491	436	.248	.501	208.0
844	817	789	761	733	677	621	565	509	453	.248	.499	215.0
873	844	815	787	758	700	642	585	527	470	.247	.497	222.0
906	876	847	817	787	728	668	609	549	490	.246	.495	230.0
937	906	876	845	814	753	692	630	569	508	.246	.493	238.0
968	936	904	873	841	778	715	652	589	526	.245	.492	246.0

Loads to the right of the heavy line are for lengths greater than 120 radii but not exceeding 150 radii.

SAFE LOADS, IN THOUSANDS OF POUNDS, FOR

BETHLEHEM STANCHIONS.

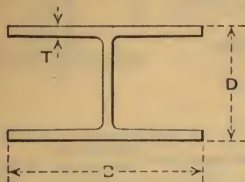

$$H_{10}^6$$

COMPUTED ACCORDING TO THE BUILDING LAWS OF NEW YORK AND CHICAGO.

Allowable Stress in Pounds per Square Inch:

$$16,000 - 70 \frac{l}{r}$$

14,000 maximum stress for Chicago.

Section Number.	Weight per Foot, Pounds.	DIMENSIONS, INCHES.			Area, Square Inches.	Least Radius of Gyration, Inches.	Maximum Safe Load for Chicago.	UNSUPPORTED LENGTH, IN FT.		
		D	T	B				7	8	9
H ₁₀ ⁶	40.0	6.216	.465	9.875	11.71	2.46	164	159	155	151
	46.0	6.356	.535	9.944	13.54	2.49	190	185	180	176
	53.0	6.512	.613	10.022	15.59	2.52	218	213	208	203
	60.0	6.666	.690	10.099	17.65	2.55	247	242	236	230
	67.0	6.818	.766	10.175	19.70	2.58	276	270	264	257
	73.0	6.946	.830	10.241	21.47	2.60	301	295	288	281
	80.0	7.096	.905	10.315	23.53	2.62	329	324	316	309
	88.0	7.265	.989	10.400	25.89	2.65	362	357	349	340

SAFE LOADS, IN THOUSANDS OF POUNDS, FOR

BETHLEHEM STANCHIONS.

$$H \frac{6}{10}$$

COMPUTED ACCORDING TO THE BUILDING LAWS OF NEW YORK AND CHICAGO.

Allowable Stress in Pounds per Square Inch:

$$16,000 - 70 \frac{l}{r}$$

14,000 maximum stress for Chicago.

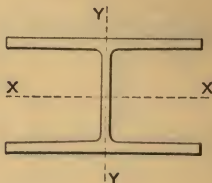

UNSUPPORTED LENGTH OF COLUMN, IN FEET.										BENDING FACTORS.		Weight per Foot, Pounds.
10	11	12	13	14	16	18	20	24	28	AXIS X-X. k	AXIS Y-Y. k'	
147	143	139	135	131	123	115	107	91	75	.443	.814	40.0
171	166	162	157	153	144	134	125	107	89	.442	.800	46.0
197	192	187	182	177	166	156	146	125	104	.441	.787	53.0
224	218	213	207	201	189	178	166	143	120	.439	.776	60.0
251	245	238	232	225	213	200	187	161	136	.438	.766	67.0
274	267	260	253	246	233	219	205	177	149	.437	.758	73.0
301	294	286	278	271	256	241	226	195	165	.435	.749	80.0
332	324	316	308	299	283	267	250	217	184	.433	.740	88.0

Loads to the right of the heavy line are for lengths greater than 120 radii but not exceeding 150 radii.

SAFE LOADS, IN THOUSANDS OF POUNDS, FOR

BETHLEHEM STANCHIONS.

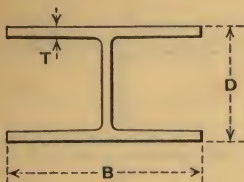

$$H \frac{6}{10}$$

COMPUTED ACCORDING TO THE
BOARD OF TRANSPORTATION OF THE
CITY OF NEW YORK.

Allowable Stress in Pounds per Square Inch:
14,000 for lengths under 54.55 radii.

20,000—110 $\frac{7}{r}$ for lengths over 54.55 radii.

Section Number.	Weight per Foot, Pounds.	DIMENSIONS, INCHES.			Area, Square Inches.	Least Radius of Gyration, Inches.	UNSUPPORTED LENGTH OF COLUMN, IN FEET.				
		D	T	B			10	11	12	13	14
$H \frac{6}{10}$	40.0	6.216	.465	9.875	11.71	2.46	164	164	159	153	146
	46.0	6.356	.535	9.944	13.54	2.49	190	190	185	177	170
	53.0	6.512	.613	10.022	15.59	2.52	218	218	214	206	197
	60.0	6.666	.690	10.099	17.65	2.55	247	247	243	234	225
	67.0	6.818	.766	10.175	19.70	2.58	276	276	273	263	253
	73.0	6.946	.830	10.241	21.47	2.60	301	301	299	288	277
	80.0	7.096	.905	10.315	23.53	2.62	329	329	328	316	305
	88.0	7.265	.989	10.400	25.89	2.65	362	362	362	350	337

SAFE LOADS, IN THOUSANDS OF POUNDS, FOR

BETHLEHEM STANCHIONS.

$$H \frac{6}{10}$$

COMPUTED ACCORDING TO THE BOARD OF TRANSPORTATION OF THE CITY OF NEW YORK.

Allowable Stress in Pounds per Square Inch:
14,000 for lengths under 54.55 radii.

20,000— $110 \frac{l}{r}$ for lengths over 54.55 radii.

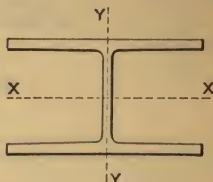

UNSUPPORTED LENGTH OF COLUMN, IN FEET.									BENDING FACTORS.		Weight per Foot, Pounds.
15	16	17	18	19	20	22	24	26	AXIS X-X. k	AXIS Y-Y. k'	
140	134	127	121	115	109	96	83	71	.443	.814	40.0
163	156	149	142	134	127	113	99	84	.442	.800	46.0
189	181	173	165	157	148	132	116	99	.441	.787	53.0
216	207	198	189	179	170	152	134	115	.439	.776	60.0
243	233	223	213	202	192	172	152	132	.438	.766	67.0
266	255	244	233	222	211	190	168	146	.437	.758	73.0
293	281	269	257	245	234	210	186	162	.435	.749	80.0
324	311	299	286	273	260	234	208	182	.433	.740	88.0

MAXIMUM SAFE SHEAR FOR BETHLEHEM GIRDER BEAMS.

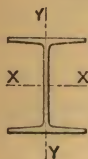

BASED UPON THE BUCKLING STRENGTH
OF THE WEBS.

ALSO THE CORRESPONDING MINIMUM
SPANS FOR GREATEST SAFE UNIFORMLY
DISTRIBUTED LOADS

AND
MOMENTS OF RESISTANCE
ABOUT AXIS X-X.

Section Number.	Nominal Depth of Beam, Inches.	Weight per Foot, Pounds.	Maximum Safe Shear, Pounds.	Minimum Span, Feet.	MOMENTS OF RESISTANCE, IN FOOT POUNDS.		
					For Fiber Stress of 18,000 Lbs. per Square Inch.	For Fiber Stress of 16,000 Lbs. per Square Inch.	For Fiber Stress of 12,000 Lbs. per Square Inch.
					R	R'	R''
G36	36 ²³ / ₃₂	300.0	334,800	19.8	1,655,000	1,472,000	1,104,000
	36 ¹ / ₂	280.0	302,400	20.5	1,546,000	1,374,000	1,031,000
	36 ¹ / ₄	260.0	275,700	20.7	1,424,000	1,266,000	949,500
	36 ¹ / ₈	250.0	261,300	20.9	1,367,000	1,215,000	911,300
	36	240.0	244,400	21.4	1,308,000	1,163,000	872,000
G33	35 ⁷ / ₈	230.0	230,300	21.9	1,251,000	1,112,000	833,900
	33 ⁵ / ₈	260.0	285,900	18.6	1,326,000	1,179,000	884,200
	33 ⁷ / ₁₆	245.0	264,100	18.9	1,247,000	1,108,000	831,000
	33 ¹ / ₄	230.0	242,500	19.3	1,167,000	1,037,000	778,000
	33 ¹ / ₈	220.0	226,600	19.6	1,112,000	988,600	741,400
	33	210.0	211,000	20.1	1,061,000	943,100	707,300
	32 ⁷ / ₈	200.0	193,200	20.9	1,009,000	896,600	672,400
G30	30 ³ / ₄	240.0	277,300	16.1	1,114,000	990,600	742,900
	30 ¹ / ₂	220.0	245,000	16.7	1,021,000	907,400	680,500
	30 ¹ / ₄	200.0	210,900	17.6	926,700	823,700	617,800
	30 ¹ / ₈	190.0	194,100	18.1	878,300	780,700	585,500
	30	180.0	179,800	18.6	834,300	741,600	556,200
	29 ⁷ / ₈	173.0	170,200	18.6	792,700	704,600	528,500
G28	28 ⁵ / ₁₆	186.0	199,400	16.2	805,800	716,300	537,200
	28 ¹ / ₈	175.0	189,500	15.8	749,600	666,300	499,700
	28	165.0	173,900	16.3	709,800	630,900	473,200
	27 ⁷ / ₈	156.0	156,400	17.1	669,100	594,800	446,100
	27 ³ / ₄	145.0	135,100	18.5	624,000	554,700	416,000
G22	22 ³ / ₈	132.0	124,500	15.1	469,300	417,200	312,900
	22 ¹ / ₄	124.0	113,700	15.5	439,800	390,900	293,200
	22 ¹ / ₈	116.0	101,400	16.2	409,700	364,200	273,200
	22	108.0	91,000	16.8	382,400	339,900	254,900
	21 ⁷ / ₈	101.0	80,800	17.6	355,200	315,700	236,800

**MAXIMUM SAFE SHEAR FOR
BETHLEHEM I BEAMS.**

BASED UPON THE BUCKLING STRENGTH
OF THE WEBS.

ALSO THE CORRESPONDING MINIMUM
SPANS FOR GREATEST SAFE UNIFORMLY
DISTRIBUTED LOADS

AND
MOMENTS OF RESISTANCE
ABOUT AXIS X-X.

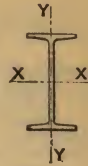

Section Number.	Nominal Depth of Beam, Inches.	Weight per Foot, Pounds.	Maximum Safe Shear, Pounds.	Minimum Span, Feet.	MOMENTS OF RESISTANCE, IN FOOT POUNDS.		
					For Fiber Stress of 18,000 Lbs. per Square Inch.	For Fiber Stress of 16,000 Lbs. per Square Inch.	For Fiber Stress of 12,000 Lbs. per Square Inch.
					R	R'	R''
B36	36 ¹⁷ / ₃₂	190.0	209,300	18.9	989,800	879,800	659,900
	36 ¹ / ₄	173.0	184,000	19.4	892,500	793,300	595,000
	36 ¹ / ₈	164.0	165,600	20.3	841,600	748,100	561,100
	36	155.0	150,300	21.2	795,600	707,200	530,400
	35 ²⁹ / ₃₂	147.0	134,500	22.5	755,100	671,200	503,400
B33	33 ¹ / ₂	165.0	183,200	17.3	791,200	703,300	527,500
	33 ⁹ / ₃₂	152.0	163,700	17.6	720,600	640,500	480,400
	33 ¹ / ₈	143.0	150,300	17.9	674,100	599,200	449,400
	33	135.0	133,700	19.0	633,400	563,000	422,300
	32 ⁷ / ₈	125.0	113,300	20.9	592,700	526,900	395,100
B30	30 ²¹ / ₃₂	163.0	204,100	13.9	711,700	632,600	474,400
	30 ⁷ / ₁₆	149.0	175,400	14.8	651,100	578,800	434,100
	30 ¹ / ₄	137.0	152,100	15.7	597,700	531,300	398,500
	30 ¹ / ₈	129.0	134,000	16.7	560,000	497,800	373,400
	30	121.0	120,700	17.5	527,000	468,400	351,300
B28	29 ⁷ / ₈	115.0	111,900	17.7	496,300	441,100	330,800
	29 ²⁵ / ₃₂	110.0	107,500	17.6	472,200	419,800	314,800
	28 ¹⁹ / ₃₂	133.0	155,100	14.1	546,100	485,400	364,000
	28 ³ / ₈	119.0	126,900	15.5	491,300	436,700	327,500
	28 ¹ / ₄	112.0	114,100	16.1	459,600	408,500	306,400
B22	22 ¹ / ₈	104.0	99,800	17.1	427,100	379,600	284,700
	22	97.0	87,900	18.1	397,700	353,500	265,100
	22 ⁷ / ₈	91.0	80,100	18.5	370,300	329,100	246,900
	22 ¹¹ / ₁₆	85.0	79,600	16.7	333,200	296,200	222,100
	22 ¹ / ₄	73.0	69,000	14.0	242,300	215,300	161,500
B22	22 ¹ / ₈	67.5	60,800	14.6	222,100	197,400	148,100
	22	62.5	54,500	15.0	203,900	181,300	135,900
	22 ¹ / ₈	58.0	51,300	14.6	187,000	166,200	124,700
	22 ³ / ₄	54.5	51,000	13.3	170,000	151,100	113,300

BETHLEHEM STEEL COMPANY

BETHLEHEM, PA.

PARTIAL LIST OF PRODUCTS.

- STRUCTURAL STEEL SHAPES:** Bethlehem Beams, Joists and Stanchions; Rolled Girder Beams, Rolled Columns; Standard Beams, Channels and Angles; Standard and Special T and Z Bars; Plain and Fabricated; Crane Rails; Rolled Steel Slabs for Column Bases.
- SHIPBUILDING SHAPES:** Ship Channels, Bulb Angles, and Hatch Sections.
- CAR BUILDING SHAPES:** Beams, Channels, Angles, Bulb Angles, Z Bars, Center and Side Sill Sections, Belt Rail, Door Spreader, and Side Stake Sections.
- PLATES:** Universal and Sheared; Circular (Heads), in all grades for all purposes; Miscellaneous Pressed Work.
- PILING:** Lackawanna Steel Sheet Piling.
- BRIDGES AND FABRICATED BUILDINGS:** Designers, Builders, Fabricators and Erectors of all types of Bridges and Steel Structures. Buckle Plates.
- RAILROAD TURNTABLES:** Bethlehem Twin-Span Turntables; Balanced and Continuous Turntables.
- FLANGED AND DISHED BOILER HEADS, SPECIAL FLANGED PRODUCTS.**
- AGRICULTURAL STEEL AND SPECIALTIES:** Standard and Special Shapes. AUXILIARY LOCOMOTIVES.
- BARs AND BANDS:** Muck Bar, Refined, Double Refined, Chain, Stay Bolt, Special Stay Bolt, Horseshoe and Engine Bolt Iron; Bessemer, Open Hearth, Electric and Alloy Steel; Concrete Reinforcing Bars.
- BILLETS, BLOOMS, SLABS, SKELP AND SHEET BARS.**
- BOILER TUBES:** Lap Welded; Charcoal Iron, and Steel.
- BOLTS, NUTS, RIVETS, SPIKES, POLE LINE MATERIAL.**
- CARS:** STEEL AND COMPOSITE FREIGHT, STEEL PASSENGER, MINE AND INDUSTRIAL.
- CAR WHEELS:** Rolled Steel.
- CASTINGS:** Steel, Iron, Brass and Bronze; Stainless Clad; Centrifugal.
- COAL:** Gas and Steaming.
- ENGINES:** Blowing, Producer Gas, and Gas.
- FERRO-MANGANESE, SPIEGELEISEN, COKE AND COKE BY-PRODUCTS.**
- FORGINGS:** Drop, Upsetter, Hammered and Hydraulically Pressed; All sizes and types; Forged Shafts.
- GEARS AND PINIONS:** Cut and Cast; Bridge Operating Machinery.
- INDUSTRIAL AND MINE TRACK WORK, STEEL MINE AND INDUSTRIAL TIES.**
- INGOT MOULDS:** All sizes.
- MACHINERY:** Hydraulic Machinery and Equipment; Special Machinery of all types and designs.
- OIL BURNING SYSTEMS.**
- OIL REFINERY EQUIPMENT.**
- PIG IRON:** Standard Grades, Special Grades, Mayari.
- PIPE AND TUBULAR GOODS:** Lap and Butt-welded, Pipe, Casing and Tubing.
- PULVERIZERS FOR COAL AND OTHER MATERIALS.**
- RAILS AND ACCESSORIES, FROGS AND SWITCHES. BETHCO RAIL ANCHORS.**
- ROLLED STEEL BLANKS FOR GEARS, PINIONS, FLY WHEELS, ETC.**
- ROLLS:** Carbon and Alloy Steel.
- SHEET AND TIN MILL PRODUCTS:** ROLL ROOFING, RIDGE ROLL.
- SPECIAL STEEL FOR AUTOMOBILE FORGINGS AND MACHINED PARTS.**
- STEEL AXLES:** For Passenger and Freight Cars, Engine and Tender Trucks; Driving; Motor; Electric and Mine Car; etc.
- TOOL STEEL, CARBON AND ALLOY:** Bethlehem Special High-Speed Tool Steel; Non-shrinkable; Rock and Mine Drill Steel; Special Tool Steel; Small Tools, etc.
- WIRE RODS, WIRE NAILS, WIRE, Woven Field and Poultry Fencing. Steel Fence Posts.**

PLANTS AT

*Bethlehem, Pa.; Lebanon, Pa.; Coatesville, Pa.; Johnstown, Pa.;
Stellton, Pa.; Lackawanna, N. Y., Sparrows Point, Md.; Wilmington, Del.*

BETHLEHEM STEEL COMPANY

General Offices

BETHLEHEM, PENNSYLVANIA

District Offices

Atlanta.....	Healey Building
Baltimore.....	Continental Building
Boston.....	Atlantic National Bank Building
Buffalo.....	Marine Trust Building
Chicago.....	People's Gas Building
Cincinnati.....	Union Trust Building
Cleveland.....	Terminal Tower
Detroit.....	New Penobscot Building
Honolulu, T. H.....	Castle and Cook Building
Houston.....	Post Dispatch Building
Los Angeles.....	Pacific Finance Building
New York.....	Cunard Building
Philadelphia.....	Widener Building
Pittsburgh.....	Oliver Building
Portland, Ore.....	American Bank Building
St. Louis.....	Arcade Building
San Francisco.....	Matson Building
Seattle.....	L. C. Smith Building

BETHLEHEM STEEL EXPORT CORPORATION
25 Broadway, New York City

Sole Exporter of Our Commercial Products

RETAILER'S LIST

[The text in this section is extremely faint and illegible, appearing to be a list of names and addresses.]

[The text at the bottom of the page is also extremely faint and illegible, possibly containing a signature or date.]

